



Please dispose of packaging for the product in a responsible manner. It is suitable for recycling. Help to protect the environment, take the packaging to the local amenity tip and place into the appropriate recycling bin.



Never dispose of electrical equipment or batteries in with your domestic waste. If your supplier offers a disposal facility please use it or alternatively use a recognised re-cycling agent. This will allow the recycling of raw materials and help protect the environment.

SIP
SIP INDUSTRIAL

machinery specialists since 1968

SIP HG400 *Inverter Plasma Cutter*



05785

**FOR HELP OR ADVICE ON THIS PRODUCT PLEASE CONTACT YOUR DISTRIBUTOR,
OR SIP DIRECTLY ON:**

TEL: 01509500400

EMAIL: sales@sip-group.com or technical@sip-group.com

www.sip-group.com

Please read and fully understand the instructions in this manual before operation. Keep this manual safe for future reference.

DECLARATION OF CONFORMITY

Declaration of Conformity

We

SIP (Industrial Products) Ltd
Gelders Hall Road
Shepshed
Loughborough
Leicestershire
LE12 9NH
England

As the manufacturer's authorised representative within the EC
declare that the

SIP HG400 Inverter Plasma Cutter - SIP Part No. 05785

Conforms to the requirements of the following directive(s), as indicated.

2014/35/EU	Low Voltage Directive
2014/30/EU	EMC Directive
2011/65/EU	RoHS Directive

And the relevant harmonised standard(s), including

EN 60974-1:2012
EN 60974-10:2014

Signed: 

Mr P. Ippaso - Managing Director - SIP (Industrial Products) Ltd
Date: 23/10/2015.



<i>Page No.</i>	<i>Description</i>
4.	Safety Symbols Used Throughout This Manual
4.	Safety Instructions
11.	Electrical Connection
12.	Guarantee
13.	Technical Specification
13.	Contents and Accessories
14.	Getting to Know Your Plasma cutter
15.	Assembly Instructions
15.	Operating Instructions
17.	Maintenance
18.	Troubleshooting
20.	Wiring Diagram
21.	Exploded Drawing
22.	Parts List
27.	Declaration of Conformity

SAFETY SYMBOLS USED THROUGHOUT THIS MANUAL



Danger / Caution: Indicates risk of personal injury and/or the possibility of damage.



Warning: Risk of electrical injury or damage!



Note: Supplementary information.

SAFETY INSTRUCTIONS



IMPORTANT: Please read the following instructions carefully, *failure to do so could lead to serious personal injury and / or damage to the plasma cutter.*

When using your inverter plasma cutter, basic safety precautions should always be followed to reduce the risk of personal injury and / or damage to the plasma cutter. Read all of these instructions before operating the plasma cutter and save this user manual for future reference.

The plasma cutter should **not** be modified or used for any application other than that for which it was designed.

This plasma cutter was designed to cut electrically conductive materials such as mild steel.

If you are unsure of its relative applications do not hesitate to contact us and we will be more than happy to advise you.

Before each use of the plasma cutter always check no parts are broken and that no parts are missing.

Always operate the plasma cutter safely and correctly.

KNOW YOUR PLASMA CUTTER: Read and understand the owner's manual and labels affixed to the plasma cutter. Learn its applications and limitations, as well as the potential hazards specific to it.

KEEP WORK AREA CLEAN AND WELL LIT: Cluttered work benches and dark areas invite accidents. Floors must not be slippery due to oil, water or sawdust etc.

DO NOT USE THE PLASMA CUTTER IN DANGEROUS ENVIRONMENTS: Do not use the plasma cutter in damp or wet locations, or expose it to rain. Provide adequate space surrounding the work area. Do not use in environments with a potentially explosive atmosphere.

NOTES

KEEP CHILDREN AND UNTRAINED PERSONNEL AWAY FROM THE WORK AREA: All visitors should be kept at a safe distance from the work area.

STORE THE PLASMA CUTTER SAFELY WHEN NOT IN USE: The plasma cutter should be stored in a dry location and disconnected from the mains supply, and out of the reach of children.

USE SAFETY CLOTHING / EQUIPMENT: Use a CE approved mask / goggles at all times with the correct shade of filter lens. A fume extractor should be used particularly where there is little or no ventilation.

PROTECT YOURSELF FROM ELECTRIC SHOCK: When working with the plasma cutter, avoid contact with any earthed items (e.g. pipes, radiators, hobs and refrigerators, etc.). It is advisable wherever possible to use an RCD (residual current device) at the mains socket.

STAY ALERT: Always watch what you are doing and use common sense. Do not operate the plasma cutter when you are tired or under the influence of alcohol or drugs.

DISCONNECT THE PLASMA CUTTER FROM THE MAINS SUPPLY: When not in use and before servicing.

NEVER LEAVE THE PLASMA CUTTER CONNECTED WHILST UNATTENDED: Turn the plasma cutter off and disconnect it from the mains supply between jobs. Do not leave the plasma cutter connected to the mains supply if no more cutting is to be done.

DO NOT ABUSE THE MAINS LEAD: Never attempt to move the plasma cutter by the mains lead or pull it to remove the plug from the mains socket. Keep the mains lead away from heat, oil and sharp edges. If the mains lead is damaged, it must be replaced by the manufacturer or its service agent or a similarly qualified person in order to avoid unwanted hazards. *All* extension cables must be checked at regular intervals and replaced if damaged.

CHECK FOR DAMAGED PARTS: Before every use of the plasma cutter, any damage found should be carefully checked to determine that it will operate correctly, safely and perform its intended function. Any damaged, split or missing parts that may affect its operation should be correctly repaired or replaced by an authorised service centre unless otherwise indicated in this instruction manual.

KEEP ALL PANELS IN PLACE: Never operate the plasma cutter with the panels removed, this is extremely dangerous.

MAINTAIN THE PLASMA CUTTER WITH CARE: Keep the earth clamp and torch consumables clean for the best and safest performance, replace as necessary.

USE ONLY RECOMMENDED ACCESSORIES: Consult this user manual, your distributor or SIP directly for recommended accessories. Follow the instructions that accompany the accessories. The use of improper accessories may cause hazards and will invalidate any warranty you may have.

SECURE THE WORKPIECE: Always use clamps to secure the workpiece. This frees up both hands to operate the plasma cutter correctly.

DO NOT OVERREACH: Keep proper footing and balance at all times.

USE THE RIGHT TOOL: Do not use the plasma cutter to do a job for which it was not designed.

SAFETY INSTRUCTIONS...cont

DO NOT OPERATE THE PLASMA CUTTER IN EXPLOSIVE ATMOSPHERES: Do not use the plasma cutter in the presence of flammable liquids, gases, dust or other combustible sources. Cutting will create sparks which can ignite the dust or fumes.

DO NOT EXPOSE THE PLASMA CUTTER TO RAIN OR USE IT IN WET CONDITIONS: Water entering the plasma cutter will greatly increase the risk of electric shock and equipment damage.

HAVE YOUR PLASMA CUTTER REPAIRED BY A QUALIFIED PERSON: The plasma cutter is in accordance with the relevant safety requirements. Repairs should only be carried out by qualified persons using original spare parts, otherwise this may result in considerable danger to the user.

- Stop operation immediately if you notice anything abnormal.
- Always disconnect the plug from the mains supply before cleaning or servicing etc.
- Be alert at all times, especially during repetitive, monotonous operations; Don't be lulled into a false sense of security.
- Use of improper accessories may cause damage to the inverter plasma cutter and surrounding area as well as increasing the risk of injury.
- **Do not** modify the inverter plasma cutter to do tasks other than those intended.
- To avoid injury, the workpiece should never be held with bare hands; The workpiece will become hot during normal cutting operations, and stay hot for a period after the cut is complete.
- Appropriate personal protective equipment **must** be worn and **must** be designed to protect against all hazards created. Severe permanent injury can result from using inappropriate or insufficient protective equipment - Eyes in particular are at risk.
- The work should be clamped firmly whilst cutting.
- **Do not** attempt any repairs to the plasma cutter unless you are a competent electrician or engineer.
- Ensure that the machine is connected to the correct supply voltage and protected by a fuse or circuit breaker of the recommend rating.
- **Never** allow the earth clamp and torch to come into contact with each other.
- Understand the operating environment; Before each use the operator should assess, understand and where possible reduce the specific risks and dangers associated with the operating environment. Bystanders should also be made aware of any risks associated with the operating environment.
- Electromagnetic fields can interfere with various electrical and electronic devices such as pacemakers; Consult your doctor before using any electric plasma cutter.
- Keep people with pacemakers away from your work area when cutting.
- Do not wrap cable around your body while cutting.
- If the plasma cutter is to be used on business premises - ensure that all local and national regulations are followed concerning the use of portable electrical appliances at work.

PARTS LIST (TORCH)

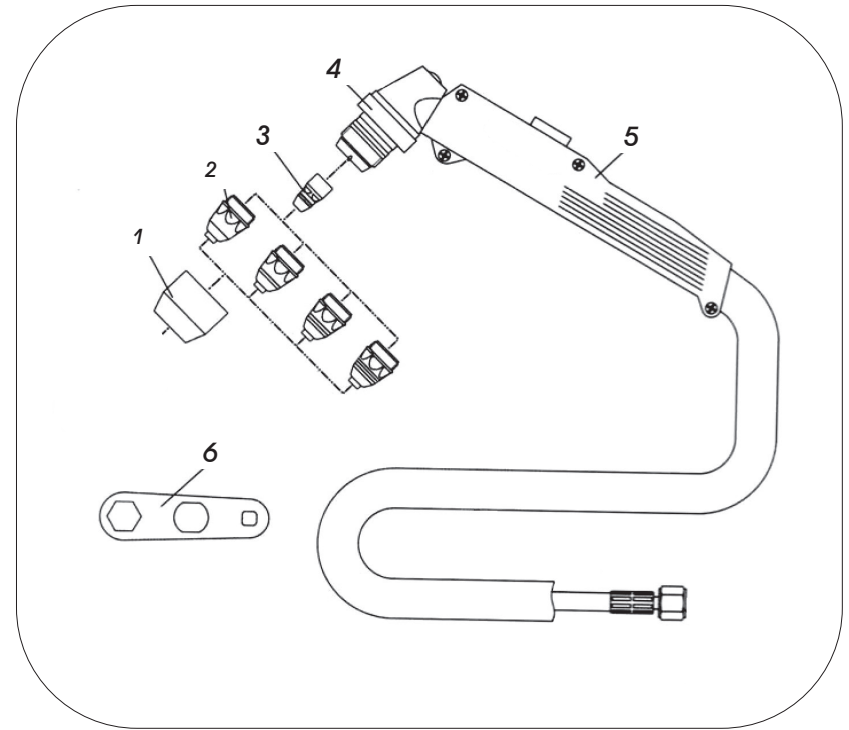

Ref. No.	Description	SIP Part No.
1.	Ceramic shield	05007
2.	1.1mm Nozzle (40A max)	05001
	1.3mm Nozzle (1 groove, 63A max)	05002
	1.5mm Nozzle (2 groove, 80A max)	05003
	1.7mm Nozzle (3 groove, 100A max)	05004
3.	Electrode	05000
4.	Insulator ring	05011
5.	Handle set	64360
6.	Spanner	64366
N/A.	Torch head	05144

PARTS LIST

Ref. No.	Description	SIP Part No.	Ref. No.	Description	SIP Part No.
1.	Handle	WE04-00040	22.	Earth lead	WE04-00112
2.	Cover	WE04-00100	23.	Plasma torch	05123
3.	Valve connector	WE04-00101	24.	Potentiometer knob	WE02-00074
4.	On/Off switch	WE04-00066	25.	LED	WE04-00088
5.	Air regulator	WE04-00102	26.	Welding potentiometer	WE04-00090
6.	Valve connector	WE04-00103	27.	Output display	WE04-00091
7.	Mains lead	WE04-00104	28.	Rectifier PCB	WE04-00113
8.	Panel	WE04-00050	29.	Insulation plate	WE04-00060
9.	Fan motor	WE04-00105	30.	Insulation plate	WE04-00064
10.	Fan holder	WE04-00062	31.	Centre panel	WE04-00093
11.	IGBT heatsink	WE04-00061	32.	Heatsink	WE04-00046
12.	Heatsink bracket	WE04-00106	33.	Pressing plate	WE04-00114
13.	Arc starting plate	WE04-00107	34.	Fast recovery diode	WE04-00115
14.	Lower panel	WE04-00083	35.	Heatsink plate	WE04-00044
15.	Foot	WE02-00019	36.	Support strip	WE04-00116
16.	Output reactor	WE04-00108	37.	Main control PCB	WE04-00117
17.	PCB	WE04-00037	38.	Rectifier bracket	WE04-00118
18.	Transformer	WE04-00109	39.	EMI filter	WE04-00071
19.	Front facia	WE04-00110	40.	Cable gland	WE04-00065
20.	Front frame	WE04-00111	41.	Air valve	WE04-00119
21.	Cable holder	WE02-00026	42.	Air pressure sensor	WE04-00120

SAFETY INSTRUCTIONS...cont

ELECTRIC SHOCK

Electric inverter plasma cutters have the potential to cause a shock that could lead to injury or death. Touching electrically 'hot' parts can cause fatal shocks and severe burns; While cutting, all metal components connected to the plasma cutter are electrically 'hot'.

- Keep your body and clothing dry. Never work in a damp area without adequate insulation against electrical shock, stay on a dry duck board, or rubber mat when dampness or sweat can not be avoided. Sweat, sea water or moisture between the body and an electrically 'hot' part or grounded metal reduces the body surfaces electrical resistance enabling dangerous and possibly lethal currents to flow through the body.
- **Never** allow live metal parts to touch bare skin or any wet clothing, be sure cutting gloves are dry.
- Before cutting, check for continuity; Be sure the earth clamp is connected to the workpiece as close to the cutting areas as possible. Grounds connected to building frame work or other remote locations from the cutting area reduce efficiency and increase the potential electric shock hazard. Avoid the possibility of the cutting current passing through lifting chains, crane cables or other electric paths.
- Frequently inspect leads for wear, splits, cracks and any other damage. **Immediately** replace those with worn or damaged insulation to avoid a possibly lethal shock from bare leads.

FIRE

During normal operation, the heat and sparks created during the cutting process have the potential to ignite flammable liquids, gases or other combustible material.

- All inflammable materials must be removed from the area.
- Have a suitable fire extinguisher available close by.
- Causes of fire and explosion include; combustibles reached by the arc, flame, flying sparks, hot slag or heated material, misuse of compressed gases and cylinders and short circuits.
- Flying sparks or falling slag can pass through cracks along pipes, through windows or doors and through walls or floor openings and out of sight of the operator; Sparks and slag can fly up-to 10 metres.
- Keep equipment clean and operable; Free of oil, grease and of metallic particles (in electrical parts) that can cause short circuits.
- If combustibles are in the area **Do not** cut; Move the work if practical to an area free of combustibles, avoid paint spray rooms, dip tanks, storage areas and ventilators. If the work can not be moved, then move the combustibles at least

SAFETY INSTRUCTIONS...cont

10 metres away and out of the reach of sparks and heat or protect against ignition with suitable and snug fitting, fire resistant covers or shields.

- Walls touching combustibles on opposite sides should not be cut, walls, ceilings and the floor near the work area should be protected by heat resistant covers or shields.
- Openings (concealed or visible) in floors or walls within 10 metres may expose combustibles to sparks.
- Combustibles adjacent to walls, ceilings, roofs or metal partitions can be ignited by radiant or conducted heat.
- After the work is done, check that the area is free of sparks, glowing embers and flames.
- An empty container that has held combustibles, or that can produce flammable or toxic vapours when heated, must never be cut, unless the container has first been cleaned. Consult HSE INDG214, HSG250 and CS15. HSE document CS15 includes information on cleaning by thorough steam or solvent/caustic cleaning followed by purging and inserting with nitrogen, carbon dioxide or water filling just below working level.
- A container with unknown contents should be treated as if it contained combustibles (see previous paragraph), **Do not** depend on sense of smell or sight to determine if it is safe to cut.
- Hollow items must be vented before cutting as they can explode.
- Explosive atmosphere; Never cut when the air may contain flammable dust, gas or liquid vapours (such as petrol).

GLARE AND BURNS

The cutting arc produces ultraviolet (UV) and infrared (IR) rays as well as extreme temperatures that can cause injury to your eyes and skin. Do not look at the cutting arc without proper eye protection.

- The electric cutting arc must not be observed with the naked eye. Always use a mask; Ensure the mask is fitted with the correct shade of filter lens for the cutting current level, and covers the entire face from neck to the top of the head.
- Gauntlet gloves should be worn to protect the hands from burns, non-synthetic overalls with buttons at the neck and wrist, or similar clothing should be worn. Greasy overalls should not be worn. Wear suitable protective footwear.
- Always wear correctly rated protective clothing which covers all areas of the body; The operator should not cut with any bare skin showing to reduce the chance of burns etc.
- Avoid oily or greasy clothing, a spark may ignite them.
- Hot metal such as electrode stubs and workpieces should never be handled without gloves.

EXPLODED DRAWING

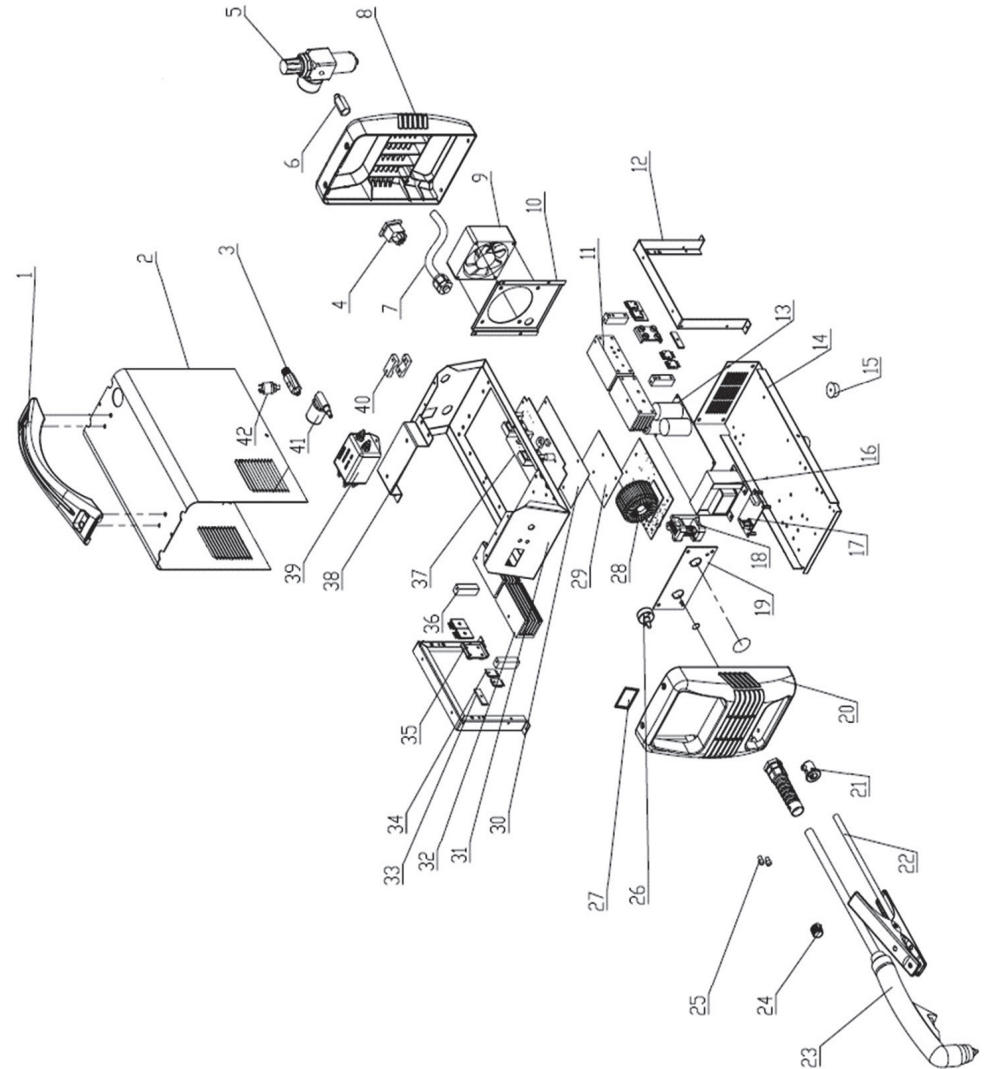

WIRING DIAGRAM

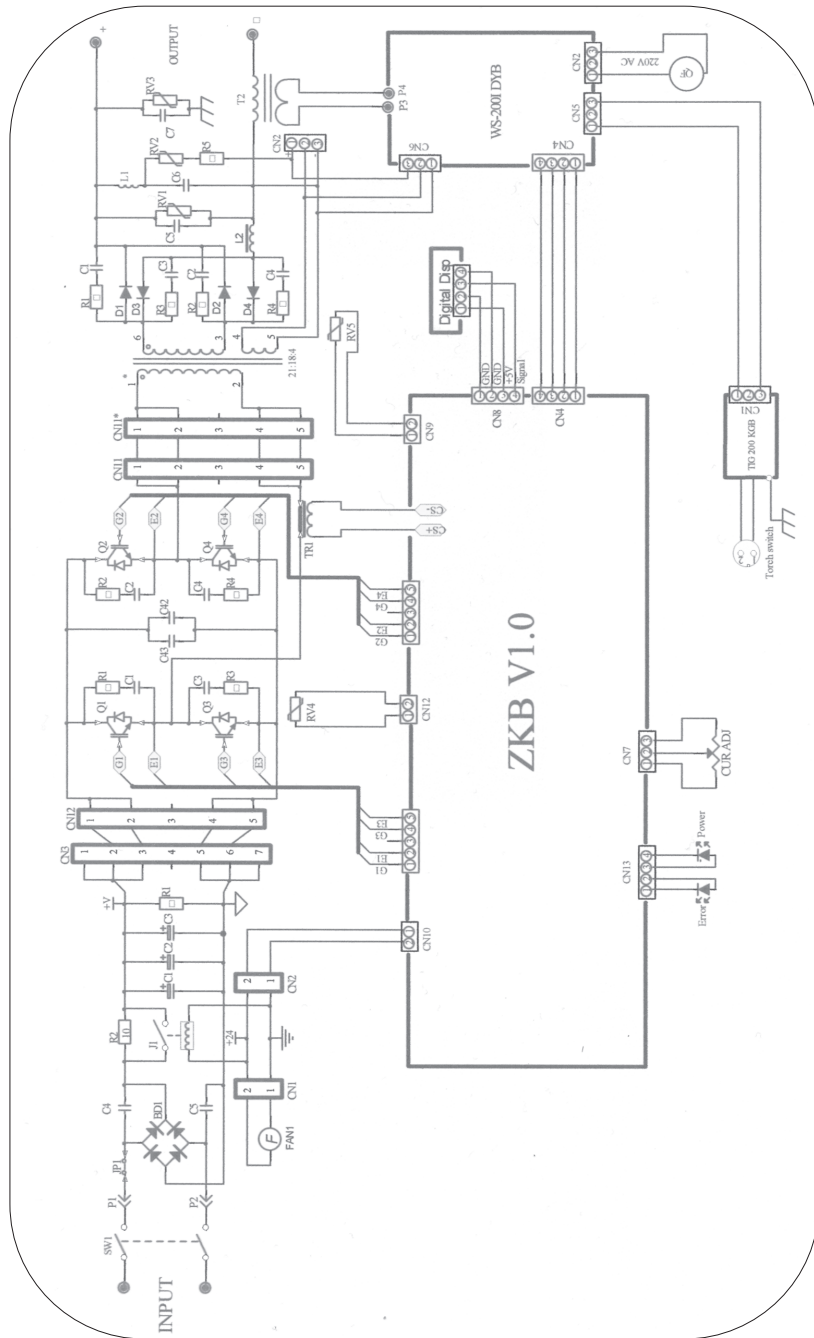

SAFETY INSTRUCTIONS...cont

- First aid facilities and a qualified first aid person should be available for each shift unless medical facilities are close by for immediate treatment of flash burns to the eyes and skin.
- Flammable hair products should not be used by persons intending to cut.
- Warn bystanders not to watch the arc and not to expose themselves to the cutting arc rays or to hot metal.
- Keep children away whilst cutting, they may not be aware that looking at an arc can cause serious eye damage.
- Protect other nearby personnel from arc rays and hot sparks with a suitable non-flammable partition.

VENTILATION

- Ventilation must be adequate to remove the smoke and fumes during cutting (see the relevant safety standard for acceptable levels).
- Toxic gases may be given off when cutting, especially if zinc or cadmium coated materials are involved, cutting should be carried out in a well ventilated area and the operator should always be alert to fume build-up.
- Areas with little or no ventilation should always use a fume extractor.
- Vapours of chlorinated solvents can form the toxic gas phosgene when exposed to U.V radiation from an electric arc. All solvents, degreasers and potential sources of these vapours must be removed from the arc area.
- Severe discomfort, illness or death can result from fumes, vapours, heat, oxygen enrichment or depletion that plasma cutting may produce. This will be prevented by adequate ventilation or using a fume extractor. **NEVER** ventilate with oxygen.
- Lead, cadmium, zinc, mercury, beryllium bearing and similar materials when cut may produce harmful concentrations of toxic fumes. Adequate ventilation must be provided for every person in the area. The operator should also wear an air supplied respirator, for beryllium both must be used.
- Metals coated with or containing materials that emit toxic fumes should not be heated unless coating is removed from the work surface. The area should be well ventilated or the operator should wear an air supplied respirator.
- Work in a confined space only while it is being ventilated and if necessary whilst wearing an air supplied respirator.
- Gas leaks in a confined space should be avoided, leaking gas in large quantities can change oxygen concentration dangerously. **DO NOT** bring gas cylinders into a confined space.
- Leaving a confined space you must shut off the gas supply at the source to prevent possible accumulation of gases in the space if down stream valves are left open. Check to be sure that the space is safe before re-entering it.

SAFETY INSTRUCTIONS...cont

- Vapours from chlorinated solvents can be decomposed by the heat of the arc (or flame) to form phosgene a highly toxic gas and other lung and eye-irritating products. The ultra violet (radiant) energy of the arc can also decompose trichloroethylene and perchlorethylene vapours to form phosgene. **DO NOT CUT** where solvent vapours can be drawn into the cutting atmosphere, or where the radiant energy can penetrate to atmospheres containing even minute amounts of trichloroethylene or perchlorethylene.



When using the plasma cutter always ensure the operator as well as those in the area use a mask / goggles with the correct shade filter lens.



Some metals and metal composites have the potential to be highly toxic; always wear a face mask.



CAUTION: The warnings and cautions mentioned in this user manual can not cover all possible conditions and situations that may occur. It must be understood by the operator that common sense and caution are factors which cannot be built into this product, but must be applied.

TROUBLESHOOTING...cont

Symptom	Possible Cause	Corrective Action
⇒ Cut quality declining.	<ul style="list-style-type: none"> ● Nozzle or electrode is burnt. ● Nozzle or electrode poorly fitted to the torch. ● Cutting angle incorrect. 	<ul style="list-style-type: none"> ● Check and replace as necessary. ● Check and refit where necessary. ● Adjust the angle of the torch during cut.
⇒ Power indication light does not illuminate when the cutter is turned on.	<ul style="list-style-type: none"> ● The LED is faulty. ● Input Fuse is blown. ● No input voltage. ● On/Off switch is faulty. 	<ul style="list-style-type: none"> ● Check / replace. ● Check / replace. ● Check supply and connections. ● Check / replace.
⇒ The low pressure / thermal overload light is illuminated.	<ul style="list-style-type: none"> ● The plasma cutter has exceeded its duty cycle. ● No compressed air input. ● Air regulator is set too low. ● Air regulator is faulty. ● Air circuit is blocked. ● Gas valve is faulty. 	<ul style="list-style-type: none"> ● Leave the plasma cutter to cool. ● Connect an adequate compressed air supply. ● Adjust the air regulator. ● Check / replace. ● Check and clear the air circuit. ● Check / replace.
⇒ Main display blank.	<ul style="list-style-type: none"> ● Display faulty. ● Cable damaged / fallen off. ● Main PCB faulty. 	<ul style="list-style-type: none"> ● Replace main display. ● Check cable and repair or replace. ● Check and replace the PCB.
⇒ No response after turning on the plasma cutter.	<ul style="list-style-type: none"> ● Input fuse is blown. ● No input voltage. ● On/Off switch is faulty ● Main control PCB is faulty. ● Transformer is faulty. 	<ul style="list-style-type: none"> ● Check / replace. ● Check supply and connections. ● Check / replace. ● Check and repair / replace. ● Check and repair / replace.



Note: If none of the above solutions work then contact your local distributor for repair, or contact SIP technical for more advise.

MAINTENANCE...cont

to be used.

7. Check the metal ring is clean on the ceramic shield, clean or replace the shield as necessary.

8. Screw the ceramic shield onto the torch.

The tip and electrode need replacing when worn.

Indication of wear are a loss off cutting capacity or that the cut is no longer 90°, also, see below.



Note: When inspecting the tip look for erosion of the hole in the centre of the tip or a build up of metal residue.

TROUBLESHOOTING



Warning: Repairs should only be carried out by suitably qualified persons.

Symptom	Possible Cause	Corrective Action
⇒ Workpiece is not cut thoroughly.	<ul style="list-style-type: none"> ●The output current is too low. ●Cutting speed is too fast. ●Torch electrode or nozzle is burnt out. ●Workpiece too thick. 	<ul style="list-style-type: none"> ●Adjust current accordingly. ●Reduce the cutting speed. ●Check and replace as necessary. ●Reduce workpiece thickness, or purchase a more powerful cutter.
⇒ Pilot is not stable during operation.	<ul style="list-style-type: none"> ●Compressed air pressure is too high or too low. ●Torch electrode or nozzle is burnt out. ●Cutting speed is too slow. ●Earth connection is poor. 	<ul style="list-style-type: none"> ●Check and adjust the air pressure. ●Check and replace as necessary. ●Accelerate the cutting speed. ●Check the earth connection is well connected.
⇒ Cut is too wide, processing quality is poor.	<ul style="list-style-type: none"> ●Nozzle or electrode is burnt. ●Nozzle or electrode poorly fitted to the torch. ●Cutting speed too slow. ●Incorrect nozzle fitted. 	<ul style="list-style-type: none"> ●Check and replace as necessary. ●Check and refit where necessary. ●Accelerate the cutting speed. ●Check and replace where necessary.

ELECTRICAL CONNECTION

WARNING! It is the responsibility of the owner and the operator to read, understand and comply with the following:

You must check all electrical products, before use, to ensure that they are safe.

You must inspect power cables, plugs, sockets and any other connectors for wear or damage.

You must ensure that the risk of electric shock is minimised by the installation of appropriate safety devices; A residual current circuit Breaker (RCCB) should be incorporated in the main distribution board. We also recommend that a residual current device (RCD) is used. It is particularly important to use an RCD with portable products that are plugged into a supply which is not protected by an RCCB. If in any doubt consult a qualified electrician.

Connecting to the power supply:

This plasma cutter is supplied without a plug fitted, it must not be connected to a 13A supply, consult the technical specification table (page13) for the required rating, if in doubt contact a qualified electrician. Before using the plasma cutter, inspect all the leads and plugs to ensure that non are damaged. If any damage is visible have the plasma cutter inspected / repaired by a suitably qualified person.

The wires for the plug are coloured in the following way:

Yellow / green	Earth
Blue	Neutral
Brown	Live

As the colours of the wires may not correspond with the markings in your plug, proceed as follows:

The wire which is coloured brown, must be connected to the terminal, which is marked L or coloured red.

The wire which is coloured blue, must be connected to the terminal marked with N or coloured black.

The wire which is coloured yellow / green should be connected to the terminal which is coloured the same or marked with this symbol \perp

Always secure the wires in the plug terminal carefully and tightly. Secure the cable in the cord grip carefully.

ELECTRICAL CONNECTION....cont



Warning: Never connect live or neutral wires to the earth terminal of the plug. Only fit an approved plug with the correct rated fuse. If in doubt consult a qualified electrician.



Note: Always make sure the mains supply is of the correct voltage and the correct fuse protection is used. In the event of replacing the fuse always replace the fuse with the same value as the original.



Note: If an extension lead is required in order to reach the mains supply; ensure that this too is rated for the correct voltage and fuse rating.

GUARANTEE

Guarantee:

This SIP inverter plasma cutter is covered by a 24 month parts and labour warranty covering failure due to manufacturers defects. This does not cover failure due to misuse or operating the plasma cutter outside the scope of this manual - any claims deemed to be outside the scope of the warranty may be subject to charges including, but not limited to parts, labour and carriage costs.

Failure to regularly clean your plasma cutter will shorten its working life and reduce performance. The warranty does not cover consumable items such as torch nozzles, electrodes & clamps etc.



Note: Proof of purchase will be required before any warranty can be honoured.

MAINTENANCE

- Clear dust from the machine at regular intervals, if used in a dirty environment the machine should be cleaned at least once a month.
- Check all connections are clean and tight, if there is any oxidization clean the connection with a mild abrasive or wire brush.
- Check all cables for damage or degradation to the insulation, replace if any found.
- Check earth clamp condition ensure they clamp tightly, replace if damaged or loose.
- If the machine is not to be used for a long time, store it in the original packing in a dry place.
- Check / Replace the torch consumables regularly (see below).

TORCH CONSUMABLES

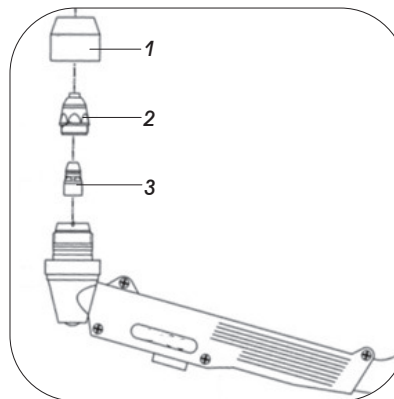

Under no circumstances should the plasma nozzle be removed or any other work be carried out on the torch with the machine switched on; Ignoring this warning could lead to serious burns or contact with high DC voltages.

If the machine has just been used for cutting, allow the cooling air to stop before switching the machine off to service the torch.

The torch should be kept free of slag at all times to ensure the free passage of air.

To assemble / dismantle the torch:

1. Invert the torch so the tip points upwards.
2. Unscrew and remove the ceramic shield (1), this item is brittle **do not drop it**.
3. Unscrew and remove the cutting tip (2).
4. Unscrew and remove the electrode (3).
5. Screw the new electrode onto torch.
6. Screw the new cutting tip onto the torch, ensure it is the correct size for the current

OPERATING INSTRUCTIONS...cont

7. Flip the safety trigger and press the torch trigger; The air will flow and after a short delay the arc will ignite. The torch should be moved steadily along the workpiece at a rate slow enough for the metal to be cut right through in one pass.
8. When the cut is complete, release the torch trigger button. The arc will immediately extinguish, but air will continue to flow for a short time. **DO NOT** turn the machine off until this cooling air has stopped flowing as this is necessary to prevent damage to the torch.

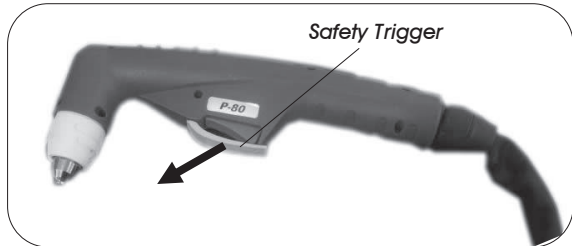

TECHNICAL SPECIFICATION

Model	SIP HG400
Input Voltage	220V - 240V ~ 50/60Hz
Input Current	16A
Output Current	15A - 40A
Output Voltage	86V - 96V
Air Pressure	3 bar - 6 bar
Air Flow	200 L/min
Max. Cutting Capacity (mild steel)	Clean cut 10mm
	Severs 12mm
Duty Cycle @ 40°C	40 amps @ 40%
	33 amps @ 60%
	25 amps @ 100%
Duty Cycle @ 20°C	40 amps @ 60%
	31 amps @ 100%
Insulation Class	F
Protection	IP21S

CONTENTS AND ACCESSORIES

HG400 Plasma Cutter	Instruction Manual
Plasma Torch (fitted to the plasma cutter)	
Earth Cable with Earth Clamp (fitted to the plasma cutter)	
Torch Consumable Accessory Set	
Air Regulator	



Note: If any of the above are missing or damaged, contact your distributor immediately.

GETTING TO KNOW YOUR PLASMA CUTTER

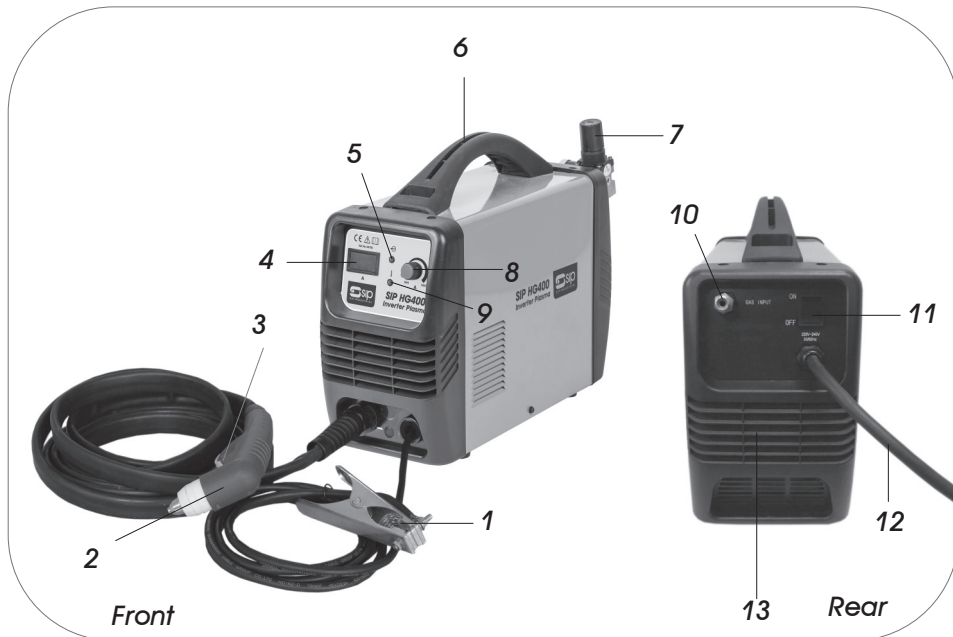

ASSEMBLY INSTRUCTIONS

FITTING THE REGULATOR

- Put some ptfе tape, or similar thread seal onto the air inlet / regulator fitting on the rear of the plasma cutter.
- Fit the regulator and turn it clockwise to fully secure it to the plasma cutter (see below).



Note: Place a spanner (not supplied) onto the air inlet / regulator fitting to stop it turning whilst fitting the regulator.

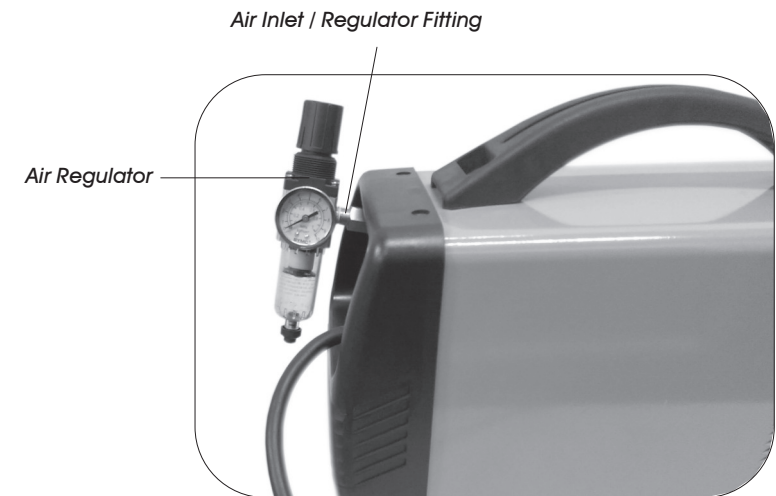

OPERATING INSTRUCTIONS

1. Connect the air supply to the regulator and adjust the air pressure as required.
2. Check the cutting tip is the correct size for the current setting and all of the torch consumables are in good condition; Replace if not.
3. Connect the earth lead to the workpiece, using an area free of rust and paint, for a good contact.
4. Connect to mains supply and switch the plasma cutter on.
5. Set the cutting current via the current control, an indication of the setting will be shown on the output display.
6. Place the torch at the edge of the workpiece with the centre of the tip slightly beyond the edge.

Ref.	Description	Ref.	Description
1.	Earth Clamp	8.	Output Control
2.	Torch	9.	Thermal Overload Indicator
3.	Torch Trigger		Low Pressure Indicator
4.	Output Display	10.	Air Inlet / Regulator Fitting
5.	Power Indicator	11.	On/Off Switch
6.	Carry Handle	12.	Mains Lead
7.	Air Regulator (supplied unfitted)	13.	Fan Inlet