



Please dispose of packaging for the product in a responsible manner. It is suitable for recycling. Help to protect the environment, take the packaging to the local amenity tip and place into the appropriate recycling bin.



Never dispose of electrical equipment or batteries in with your domestic waste. If your supplier offers a disposal facility please use it or alternatively use a recognised re-cycling agent. This will allow the recycling of raw materials and help protect the environment.

Sip
SIP INDUSTRIAL

machinery specialists since 1968

SIP HG1800DC

Tig/Arc Inverter Welder



05775

**FOR HELP OR ADVICE ON THIS PRODUCT PLEASE CONTACT YOUR DISTRIBUTOR,
OR SIP DIRECTLY ON:**

TEL: 01509500400

EMAIL: sales@sjp-group.com or technical@sjp-group.com

www.sjp-group.com

Please read and fully understand the instructions in this manual before operation. Keep this manual safe for future reference.

DECLARATION OF CONFORMITY

Declaration of Conformity

We

SIP (Industrial Products) Ltd
Gelders Hall Road
Shepshed
Loughborough
Leicestershire
LE12 9NH
England

As the manufacturer's authorised representative within the EC
declare that the

SIP HG1800DC Tig/Arc Inverter Welder - SIP Part. No. 05775

Conforms to the requirements of the following directive(s), as indicated.

2014/35/EU	Low Voltage Directive
2014/30/EU	EMC Directive
2011/65/EU	RoHS Directive

And the relevant harmonised standard(s), including

EN 60974-1:2012
EN 60974-10:2014

Signed: 

Mr P. Ippaso - Managing Director - SIP (Industrial Products) Ltd
Date: 23/01/2016.



PARTS LIST (TIG TORCH)

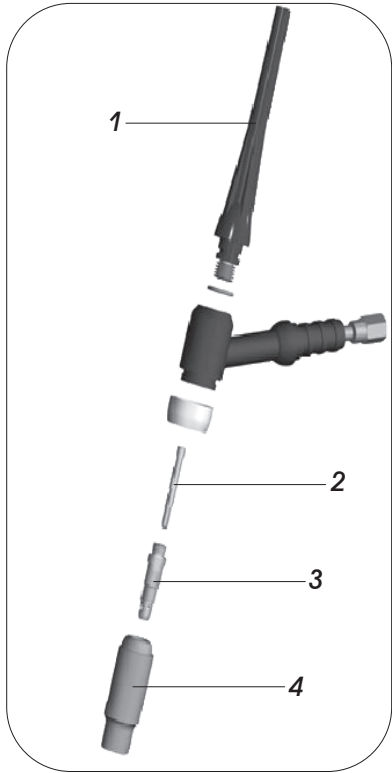

Ref. No.	Description	Sip Part No.
1.	Black cap	05147
	Black cap (long)	05148
2.	1.0mm collet	15051
	1.6mm collet	15052
	2.4mm collet	15053
3.	0.5 - 1.0mm collet body	15054
	1.6mm collet body	15055
	2.0 - 2.4mm collet body	15056
4.	No 5 ceramic nozzle	15071
	No 6 ceramic nozzle	15057
	No 7 ceramic nozzle	15073
N/A.	1.0mm Red tip tungsten	15059
	1.6mm Thoriated red tip tungsten 2%	15060
	2.4mm Red tip tungsten	15061
	2.4mm Green tip tungsten	15062
	Tig Torch Complete	05016

CONTENTS

Page No.	Description
4.	Safety Symbols Used Throughout This Manual
4.	Safety Instructions
11.	Electrical Connection
12.	Guarantee
13.	Technical Specification
14.	Contents and Accessories
15.	Getting to Know Your Welder
16.	Operating Instructions
21.	Maintenance
22.	Troubleshooting
23.	Wiring Diagram
24.	Exploded Drawing
25.	Parts List
27.	Declaration of Conformity

SAFETY SYMBOLS USED THROUGHOUT THIS MANUAL



Danger / Caution: Indicates risk of personal injury and/or the possibility of damage.



Warning: Risk of electrical injury or damage!



Note: Supplementary information.

SAFETY INSTRUCTIONS



IMPORTANT: Please read the following instructions carefully, *failure to do so could lead to serious personal injury and / or damage to the welder.*

When using your inverter welder, basic safety precautions should always be followed to reduce the risk of personal injury and / or damage to the welder.

Read all of these instructions before operating the welder and save this user manual for future reference.

The welder should **not** be modified or used for any application other than that for which it was designed.

This welder was designed to supply electric current for Tig or Arc welding.

If you are unsure of its relative applications do not hesitate to contact us and we will be more than happy to advise you.

Before each use of the welder always check no parts are broken and that no parts are missing.

Always operate the welder safely and correctly.

KNOW YOUR WELDER: Read and understand the owner's manual and labels affixed to the welder. Learn its applications and limitations, as well as the potential hazards specific to it.

KEEP WORK AREA CLEAN AND WELL LIT: Cluttered work benches and dark areas invite accidents. Floors must not be slippery due to oil, water or sawdust etc.

DO NOT USE THE WELDER IN DANGEROUS ENVIRONMENTS: Do not use the welder in damp or wet locations, or expose it to rain. Provide adequate space surrounding the work area. Do not use in environments with a potentially explosive atmosphere.

KEEP CHILDREN AND UNTRAINED PERSONNEL AWAY FROM THE WORK AREA: All visitors should be kept at a safe distance from the work area.

PARTS LIST

Ref. No.	Description	Sip Part No.	Ref. No.	Description	Sip Part No.
1.	Handle	WE04-00075	21.	Plastic panel	WE04-00050
2.	Cover	WE04-00076	22.	Potentiometer knob	WE01-00091
3.	Valve connector	WE04-00077	23.	TIG switch	WE04-00087
4.	Valve	WE04-00078	24.	LED	WE04-00088
5.	Tension disc	WE04-00065	25.	Coupler	WE04-00089
6.	On/Off switch	WE04-00066	26.	Welding potentiometer	WE04-00090
7.	Mains lead	WE04-00079	27.	Output display	WE04-00091
8.	Plastic panel	WE04-00050	28.	Rectifier PCB	WE04-00092
9.	Fan motor	WE04-00080	29.	Insulation plate	WE04-00060
10.	Fan cover	WE04-00062	30.	Insulation plate	WE04-00064
11.	IGBT heat sink	WE04-00061	31.	Centre panel	WE04-00093
12.	Heatsink bracket	WE04-00081	32.	Heat sink	WE04-00046
13.	Arc PCB	WE04-00082	33.	Plate	WE04-00094
14.	Lower panel	WE04-00083	34.	Fast recovery diode	WE07-00014
15.	Foot	WE02-00019	35.	Heatsink plate	WE04-00044
16.	PCB	WE04-00037	36.	Spacer	WE04-00043
17.	Transformer	WE04-00084	37.	Main control PCB	WE04-00095
18.	Front facia	WE04-00085	38.	Filter bracket	WE04-00096
19.	Dinse socket	WE02-00114	39.	Filter	WE04-00097
20.	TIG torch socket	WE04-00086	N/A.	Arc welding accessory kit	02690

EXPLODED DRAWING

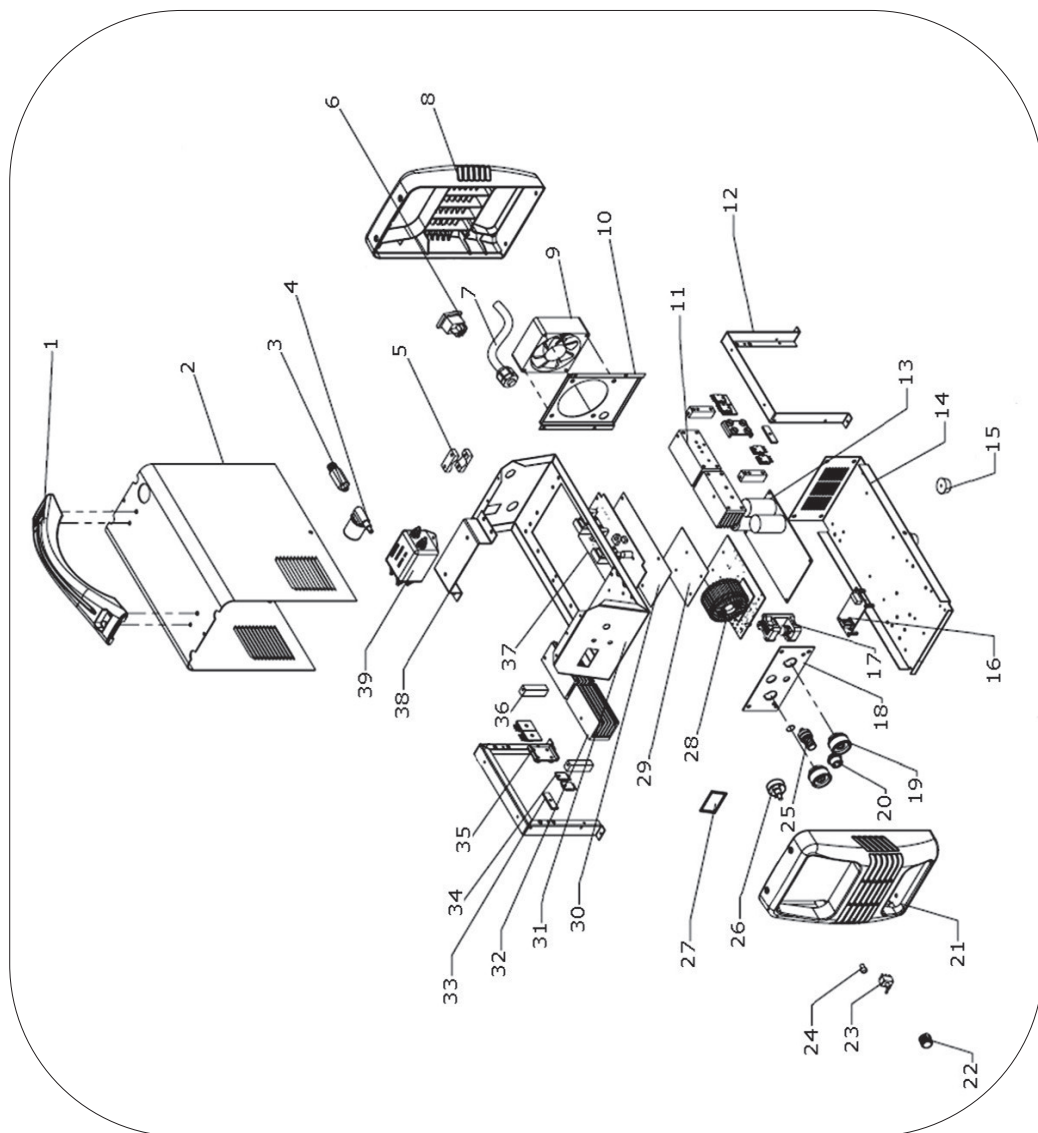

SAFETY INSTRUCTIONS...cont

STORE THE WELDER SAFELY WHEN NOT IN USE: The welder should be stored in a dry location and disconnected from the mains supply, and out of the reach of children.

USE SAFETY CLOTHING / EQUIPMENT: Use a CE approved welding mask at all times with the correct shade of filter lens. A fume extractor should be used particularly where there is little or no ventilation.

PROTECT YOURSELF FROM ELECTRIC SHOCK: When working with the welder, avoid contact with any earthed items (e.g. pipes, radiators, hobs and refrigerators, etc.). It is advisable wherever possible to use an RCD (residual current device) at the mains socket.

STAY ALERT: Always watch what you are doing and use common sense. Do not operate the welder when you are tired or under the influence of alcohol or drugs.

DISCONNECT THE WELDER FROM THE MAINS SUPPLY: When not in use and before servicing.

AVOID UNINTENTIONAL STRIKING: Make sure the switch is in the **OFF** position before connecting the welder to the mains supply.

NEVER LEAVE THE WELDER CONNECTED WHILST UNATTENDED: Turn the welder off and disconnect it from the mains supply between jobs. Do not leave the welder connected to the mains supply if no more welding is to be done.

DO NOT ABUSE THE MAINS LEAD: Never attempt to move the welder by the mains lead or pull it to remove the plug from the mains socket. Keep the mains lead away from heat, oil and sharp edges. If the mains lead is damaged, it must be replaced by the manufacturer or its service agent or a similarly qualified person in order to avoid unwanted hazards. *All* extension cables must be checked at regular intervals and replaced if damaged.

CHECK FOR DAMAGED PARTS: Before every use of the welder, any damage found should be carefully checked to determine that it will operate correctly, safely and perform its intended function. Any damaged, split or missing parts that may affect its operation should be correctly repaired or replaced by an authorised service centre unless otherwise indicated in this instruction manual.

KEEP ALL PANELS IN PLACE: Never operate the welder with the panels removed, this is extremely dangerous.

MAINTAIN THE WELDER WITH CARE: Keep the earth clamp and Tig torch consumables clean for the best and safest performance.

USE ONLY RECOMMENDED ACCESSORIES: Consult this user manual, your distributor or SIP directly for recommended accessories. Follow the instructions that accompany the accessories. The use of improper accessories may cause hazards and will invalidate any warranty you may have.

SECURE THE WORK-PIECE: Always use welding clamps to secure the work piece. This frees up both hands to operate the welder correctly.

DO NOT OVERREACH: Keep proper footing and balance at all times.

USE THE RIGHT TOOL: Do not use the welder to do a job for which it was not designed.

DO NOT OPERATE THE WELDER IN EXPLOSIVE ATMOSPHERES: Do not use the welder in the presence of flammable liquids, gases, dust or other combustible sources. Welding will create sparks which can ignite the dust or fumes.

SAFETY INSTRUCTIONS...cont

DO NOT EXPOSE THE WELDER TO RAIN OR USE IT IN WET CONDITIONS: Water entering the welder will greatly increase the risk of electric shock and equipment damage.

HAVE YOUR WELDER REPAIRED BY A QUALIFIED PERSON: The welder is in accordance with the relevant safety requirements. Repairs should only be carried out by qualified persons using original spare parts, otherwise this may result in considerable danger to the user.

- Stop operation immediately if you notice anything abnormal.
- Always disconnect the plug from the mains supply before cleaning or servicing etc.
- Be alert at all times, especially during repetitive, monotonous operations; Don't be lulled into a false sense of security.
- Use of improper accessories may cause damage to the inverter welder and surrounding area as well as increasing the risk of injury.
- **Do not** modify the inverter welder to do tasks other than those intended.
- To avoid injury, the work-piece should never be held with bare hands; The work-piece will become hot during normal welding operations, and stay hot for a period after the weld is complete.
- Appropriate personal protective equipment **must** be worn and **must** be designed to protect against all hazards created. Severe permanent injury can result from using inappropriate or insufficient protective equipment - Eyes in particular are at risk.
- The work should be clamped firmly whilst welding, If its loose it could result in personal injury or damage to the machine or item that is being welded.
- **Do not** attempt any repairs to the welder unless you are a competent electrician or engineer.
- Ensure that the machine is connected to the correct supply voltage and protected by a fuse or circuit breaker of the recommend rating.
- **Never** allow the earth clamp and electrode holder to come into contact with each other.
- Understand the operating environment; Before each use the operator should assess, understand and where possible reduce the specific risks and dangers associated with the operating environment. Bystanders should also be made aware of any risks associated with the operating environment.
- Electromagnetic fields can interfere with various electrical and electronic devices such as pacemakers; Consult your doctor before using any electric welder or cutting device.
- Keep people with pacemakers away from your welding area when welding.
- Do not wrap cable around your body while welding.
- If the welder is to be used on business premises - ensure that all local and national regulations are followed concerning the use of portable electrical appliances at work.

WIRING DIAGRAM

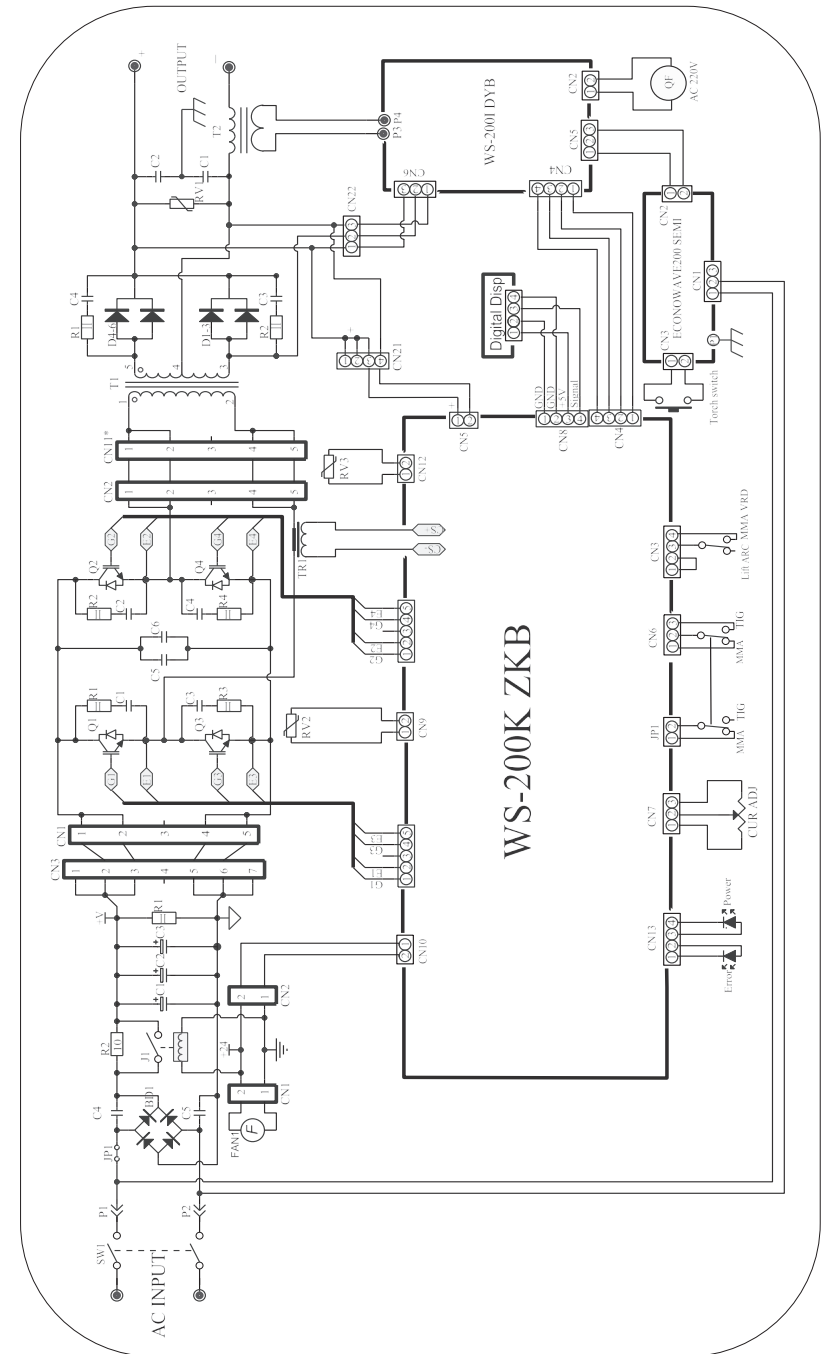

TROUBLESHOOTING

Symptom	Possible Cause	Corrective Action
⇒ <i>Cooling Fan Not Running.</i>	<ul style="list-style-type: none"> • Cooling fan broken. • Cable damaged / fallen off. 	<ul style="list-style-type: none"> • Replace the fan. • Check cable and repair or replace.
⇒ <i>No Gas Output.</i>	<ul style="list-style-type: none"> • No Gas Input. • Main PCB Faulty. • Electro-Magnetic Valve Faulty. • Gas Path Blocked. 	<ul style="list-style-type: none"> • Check supply bottle is not empty and the regulator is open. • Check and Replace The PCB. • Check and Replace The Valve. • Check and Clear Pipe and Connections.
⇒ <i>Fault Light Illuminated.</i>	<ul style="list-style-type: none"> • Internal Temperature of The Welder is Too High. • Thermal Relay is Faulty. • Over / Under Input Voltage is More than 15%. 	<ul style="list-style-type: none"> • Allow the Welder To Cool Before Commencing Weld. • Check and Replace Faulty Relay. • Check the Input Supply.
⇒ <i>Main Display Blank.</i>	<ul style="list-style-type: none"> • Display Faulty. • Cable damaged / fallen off. • Main PCB Faulty. 	<ul style="list-style-type: none"> • Replace Main Display. • Check cable and repair or replace. • Check and Replace The PCB.



Note: If none of the above solutions work then contact your local distributor for repair, or contact SIP technical for more advise.

SAFETY INSTRUCTIONS...cont

ELECTRIC SHOCK

Electric inverter welders have the potential to cause a shock that could lead to injury or death. Touching electrically 'hot' parts can cause fatal shocks and severe burns; While welding, all metal components connected to the welder are electrically 'hot'.

- Keep your body and clothing dry. Never work in a damp area without adequate insulation against electrical shock, stay on a dry duck board, or rubber mat when dampness or sweat can not be avoided. Sweat, sea water or moisture between the body and an electrically 'hot' part or grounded metal reduces the body surfaces electrical resistance enabling dangerous and possibly lethal currents to flow through the body.
- **Never** allow live metal parts to touch bare skin or any wet clothing, be sure welding gloves are dry.
- Before welding, check for continuity; Be sure the earth clamp is connected to the work-piece as close to the welding areas as possible. Grounds connected to building frame work or other remote locations from the welding area reduce efficiency and increase the potential electric shock hazard. Avoid the possibility of the welding current passing through lifting chains, crane cables or other electric paths.
- Frequently inspect leads for wear, splits, cracks and any other damage. **Immediately** replace those with worn or damaged insulation to avoid a possibly lethal shock from bare leads.

FIRE

During normal operation, the heat and sparks created during the welding process have the potential to ignite flammable liquids, gases or other combustible material.

- All inflammable materials must be removed from the area.
- Have a suitable fire extinguisher available close by.
- Causes of fire and explosion include; combustibles reached by the arc, flame, flying sparks, hot slag or heated material, misuse of compressed gases and cylinders and short circuits.
- Flying sparks or falling slag can pass through cracks along pipes, through windows or doors and through walls or floor openings and out of sight of the operator; Sparks and slag can fly up-to 10 metres.
- Keep equipment clean and operable; Free of oil, grease and of metallic particles (in electrical parts) that can cause short circuits.
- If combustibles are in the area. **Do not** weld, move the work if practical to an area free of combustibles, avoid paint spray rooms, dip tanks, storage areas and ventilators. If the work can not be moved, then move the combustibles at

SAFETY INSTRUCTIONS...cont

- least 10 metres away and out of the reach of sparks and heat or protect against ignition with suitable and snug fitting, fire resistant covers or shields.
- Walls touching combustibles on opposite sides should not be welded on, walls, ceilings and the floor near the work area should be protected by heat resistant covers or shields.
- Openings (concealed or visible) in floors or walls within 10 metres may expose combustibles to sparks.
- Combustibles adjacent to walls, ceilings, roofs or metal partitions can be ignited by radiant or conducted heat.
- After the work is done, check that the area is free of sparks, glowing embers and flames.
- An empty container that has held combustibles, or that can produce flammable or toxic vapours when heated, must never be welded, unless the container has first been cleaned. Consult HSE INDG214, HSG250 and CS15. HSE document CS15 includes information on cleaning by thorough steam or solvent/caustic cleaning followed by purging and inserting with nitrogen, carbon dioxide or water filling just below working level.
- A container with unknown contents should be treated as if it contained combustibles (see previous paragraph), **Do not** depend on sense of smell or sight to determine if it is safe to weld.
- Hollow items must be vented before welding as they can explode.
- Explosive atmosphere; Never weld when the air may contain flammable dust, gas or liquid vapours (such as petrol).

GLARE AND BURNS

The welding arc produces ultraviolet (UV) and infrared (IR) rays as well as extreme temperatures that can cause injury to your eyes and skin. Do not look at the welding arc without proper eye protection.

- The electric welding arc must not be observed with the naked eye. Always use a welding mask; Ensure the welding mask is fitted with the correct shade of filter lens for the welding current level, and covers the entire face from neck to the top of the head.
- Welding gauntlet gloves should be worn to protect the hands from burns, non-synthetic overalls with buttons at the neck and wrist, or similar clothing should be worn. Greasy overalls should not be worn. Wear suitable protective footwear.
- Always wear correctly rated protective clothing which covers all areas of the body; The operator should not weld with any bare skin showing to reduce the chance of burns etc.
- Avoid oily or greasy clothing, a spark may ignite them.
- Hot metal such as electrode stubs and work-pieces should never be handled

MAINTENANCE

- Clear dust from the machine at regular intervals, if used in a dirty environment the machine should be cleaned at least once a month.
- Check all connections are clean and tight, if there is any oxidization clean the connection with a mild abrasive or wire brush.
- Check all cables for damaged or degradation to the insulation, replace if any found.
- Check the earth clamp condition ensure they clamp tightly, replace if damaged or loose.
- If the machine is not to be used for a long time, store it in the original packing a dry place.
- Check / Replace the torch consumables regularly.

OPERATING INSTRUCTIONS...cont



Note: Be aware that the electrode is now live, simply touching any part of the workpiece will create a spark.

- Place a face mask / helmet over your face (not supplied).
- Initiate the arc.
- When the arc is created, proceed steadily in one direction keeping the gap between the electrode and the workpiece constant.
- When the weld is complete simply remove the electrode from the workpiece.
- Remove any excess weld / slag with a wire brush / hammer (not supplied).
- Once all work has been done, switch the machine off.

SAFETY INSTRUCTIONS...cont

without gloves.

- First aid facilities and a qualified first aid person should be available for each shift unless medical facilities are close by for immediate treatment of flash burns to the eyes and skin.
- Flammable hair products should not be used by persons intending to weld.
- Warn bystanders not to watch the arc and not to expose themselves to the welding arc rays or to hot metal.
- Keep children away whilst welding, they may not be aware that looking at an arc can cause serious eye damage.
- Protect other nearby personnel from arc rays and hot sparks with a suitable non-flammable partition.

VENTILATION

- Ventilation must be adequate to remove the smoke and fumes during welding (see the relevant safety standard for acceptable levels).
- Toxic gases may be given off when welding, especially if zinc or cadmium coated materials are involved, welding should be carried out in a well ventilated area and the operator should always be alert to fume build-up.
- Areas with little or no ventilation should always use a fume extractor.
- Vapours of chlorinated solvents can form the toxic gas phosgene when exposed to U.V radiation from an electric arc. All solvents, degreasers and potential sources of these vapours must be removed from the arc area.
- Severe discomfort, illness or death can result from fumes, vapours, heat, oxygen enrichment or depletion that welding (or cutting) may produce. This will be prevented by adequate ventilation or using a fume extractor. **NEVER** ventilate with oxygen.
- Lead, cadmium, zinc, mercury, beryllium bearing and similar materials when welded may produce harmful concentrations of toxic fumes. Adequate ventilation must be provided for every person in the area. The operator should also wear an air supplied respirator, for beryllium both must be used.
- Metals coated with or containing materials that emit toxic fumes should not be heated unless coating is removed from the work surface. The area should be well ventilated or the operator should wear an air supplied respirator.
- Work in a confined space only while it is being ventilated and if necessary whilst wearing an air supplied respirator.
- Gas leaks in a confined space should be avoided, leaking gas in large quantities can change oxygen concentration dangerously. **DO NOT** bring gas cylinders into a confined space.
- Leaving a confined space you must shut off the gas supply at the source to prevent possible accumulation of gases in the space if down stream valves are left open. Check to be sure that the space is safe before re-entering it.

SAFETY INSTRUCTIONS...cont

- Vapours from chlorinated solvents can be decomposed by the heat of the arc (or flame) to form phosgene a highly toxic gas and other lung and eye-irritating products. The ultra violet (radiant) energy of the arc can also decompose trichloroethylene and perchlorethylene vapours to form phosgene. **DO NOT WELD** or cut where solvent vapours can be drawn into the welding atmosphere, or where the radiant energy can penetrate to atmospheres containing even minute amounts of trichloroethylene or perchlorethylene.



When using the welder always ensure the operator as well as those in the area use a welding mask with the correct shade filter lens.



Some metals and metal composites have the potential to be highly toxic; always wear a face mask .



CAUTION: The warnings and cautions mentioned in this user manual can not cover all possible conditions and situations that may occur. It must be understood by the operator that common sense and caution are factors which cannot be built into this product, but must be applied.

OPERATING INSTRUCTIONS...cont



Note: The table (on previous page) is a guide only; always try a short weld test at the setting selected. It is normal to make minor adjustments to achieve the required weld.

FITTING THE ELECTRODE HOLDER & EARTH CLAMP

- To connect the earth lead simply line up the tab on the dinse connector with the cut out on the negative dinse socket and turn clockwise to secure.
- Connect the electrode holder lead in the same way, but connect to the positive socket.

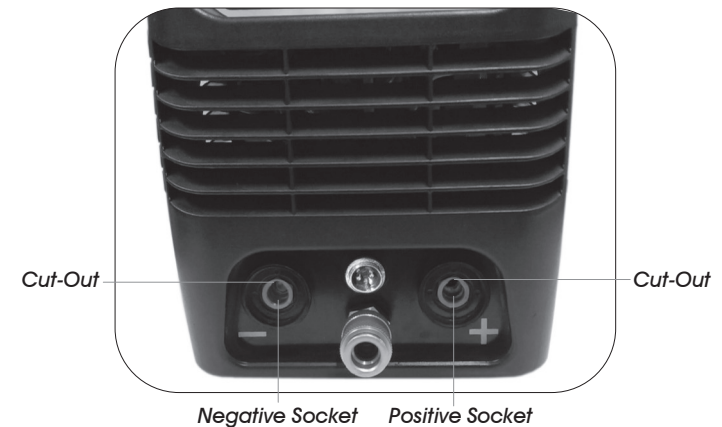

PREPARATION FOR WELDING

- Clean the area to be welded, and the earthing point of all rust, paint and contaminants etc.
- Place the earth clamp on to a cleaned area of the workpiece.
- Connect the welder to the electrical supply.

WELDING



Caution: Ensure all protective equipment is worn and bystanders are not in the vicinity.

- Switch the welder on.
- Set the required welding current.
- Fit the required electrode securely into the electrode holder.

OPERATING INSTRUCTIONS...cont

- Place the earth clamp onto a cleaned area of the workpiece.
- Fit the ground tungsten into the TIG torch head.
- Connect the regulator (not supplied) onto the gas bottle.
- Connect the gas pipe from the rear of the welder onto the regulator.
- Turn the regulator on.
- Connect the welder to the electrical supply.

WELDING



Caution: Ensure all protective equipment is worn and bystanders are not in the vicinity.

- Switch the welder on.
- Set the mode selection switch to Tig.
- Set the required welding current.
- Place a face mask / helmet over your face (not supplied).
- Initiate the HF arc and proceed with the weld.
- Once all work has been done, switch the machine and the gas off.

ARC WELDING

There are no hard and fast rules by which a particular gauge of electrode is selected, usually this is determined by the type of welding required and the thickness of the workpiece e.g. a butt weld in 1.5mm (1/16") sheet metal can be done by a 1.6mm or 2.0mm electrode, the difference being that the 2.0mm electrode will do the job more quickly.

The table below gives a guide as to which electrode is most suitable according to the material thickness. This table is only a guide, and values given are an indication only.

These welding current values are for the E6013 electrodes, for other types of electrode consult their data sheet.

Electrode Size mm	Material Thickness mm	Welding Current (A)
1.6	1 - 1.6	25 - 40
2.0	1.6 - 2.6	40 - 70
2.5	2.6 - 4.0	60 - 100
3.25	3.0 - 5.0	80 - 130
4.0	5.0 - 7.0	130 - 170

ELECTRICAL CONNECTION

WARNING! It is the responsibility of the owner and the operator to read, understand and comply with the following:

You must check all electrical products, before use, to ensure that they are safe. You must inspect power cables, plugs, sockets and any other connectors for wear or damage.

You must ensure that the risk of electric shock is minimised by the installation of appropriate safety devices; A residual current circuit Breaker (RCCB) should be incorporated in the main distribution board. We also recommend that a residual current device (RCD) is used. It is particularly important to use an RCD with portable products that are plugged into a supply which is not protected by an RCCB. If in any doubt consult a qualified electrician.

Connecting to the power supply:

This welder is supplied without a plug fitted, it must not be connected to a 13A supply, consult the technical specification table (page 13) for the required rating, if in doubt contact a qualified electrician. Before using the welder, inspect all the leads and plugs to ensure that non are damaged. If any damage is visible have the welder inspected / repaired by a suitably qualified person.

The wires for the plug are coloured in the following way:

Yellow / green	Earth
Blue	Neutral
Brown	Live

As the colours of the wires may not correspond with the markings in your plug, proceed as follows:

The wire which is coloured brown, must be connected to the terminal, which is marked L or coloured red.

The wire which is coloured blue, must be connected to the terminal marked with N or coloured black.

The wire which is coloured yellow / green should be connected to the terminal which is coloured the same or marked with this symbol \perp

Always secure the wires in the plug terminal carefully and tightly. Secure the cable in the cord grip carefully.

ELECTRICAL CONNECTION...cont



Warning: Never connect live or neutral wires to the earth terminal of the plug. Only fit an approved plug with the correct rated fuse. If in doubt consult a qualified electrician.



Note: Always make sure the mains supply is of the correct voltage and the correct fuse protection is used. In the event of replacing the fuse always replace the fuse with the same value as the original.



Note: If an extension lead is required in order to reach the mains supply; ensure that this too is rated for the correct voltage and fuse rating.

GUARANTEE

Guarantee:

This SIP inverter welder is covered by a 24 month parts and labour warranty covering failure due to manufacturers defects. This does not cover failure due to misuse or operating the welder outside the scope of this manual - any claims deemed to be outside the scope of the warranty may be subject to charges including, but not limited to parts, labour and carriage costs.

Failure to regularly clean your welder will shorten its working life and reduce performance. The warranty does not cover consumable items such as ceramics, collets & clamps etc.



Note: Proof of purchase will be required before any warranty can be honoured.

OPERATING INSTRUCTIONS...cont

TUNGSTEN

The required tungsten diameter is determined by the thickness of the material to be welded, for each tungsten size there are strict current limits which should be adhered to. Too great a current causes excessive tungsten consumption and weld pool contamination, whilst a too small a current causes arc instability.

The table below gives a guide as to which tungsten is most suitable according to the material thickness. This table is only a guide, and values given are a indication only. These welding current values are for thorium 2% (red) tungsten electrodes.

Welding Thickness (mm)	Tungsten Diameter (mm)	Welding Current Steel (amps)	Welding Current Stainless Steel (amps)
0.5	1.0	30-60	15-30
1.0	1.6	50-70	50-70
1.5	1.6	90-110	60-90
2.0	1.6	100-130	80-100
3.0	2.4	120-140	100-130
4.0	2.4	150-200	130-200



Note: The above is a guide only; always try a short weld test at the setting selected. It is normal to make minor adjustments to achieve the required weld.

PREPARING THE TUNGSTEN

It is important to choose a tungsten with the correct diameter for the current to be used. The tungsten will normally protrude from the ceramic nozzle by 2 or 3mm, in order to gain access to areas such as internal corners the tungsten can be made to protrude by up to 8mm. The tungsten should be sharpened facing the grinding wheel (see right picture). The tip should be perfectly concentric in order to avoid arc deviations. It is best to regularly inspect the tungsten to maintain peak condition.

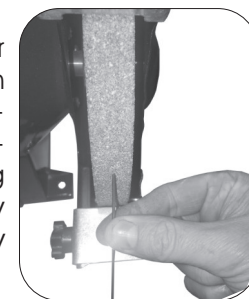

PREPARATION FOR WELDING

- Clean the area to be welded, and the earthing point of all rust, paint and contaminants etc.

OPERATING INSTRUCTIONS

TIG WELDING

FITTING THE GAS PIPE



Note: In order to use gas you will need to purchase gas and a gas regulator (inc. fittings) suitable for the type of welding required.

- Screw the gas pipe on to the gas fitting on the rear of the machine, tighten the nut using a spanner (not supplied).

FITTING THE TORCH & EARTH LEAD

- To connect the earth lead simply line up the tab on the dinse connector with the cut out on the positive dinse socket and turn clockwise to secure.
- Connect the torch power lead in the same way, but connect to the negative socket.
- The torch trigger lead is fitted to the torch trigger connection; Line up the cut-out on the lead with the tab on the socket. Push the plug in and secure in place by tightening the fitting on the plug.
- Connect the gas pipe on the torch to the gas fitting.

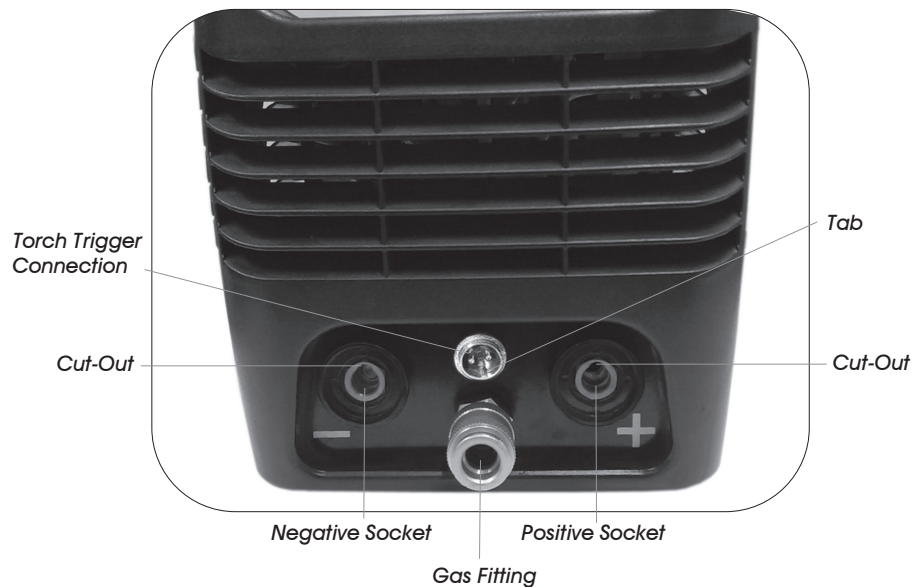

TECHNICAL SPECIFICATION

Model	SIP HG1800DC
Input Voltage	230V ~ 50Hz
Input Current	16A
Output Current - Tig	10A - 160A
Output Voltage - Tig	10.4V - 16.4V
Output Current - Arc	10A - 140A
Output Voltage - Arc	20.4V - 25.6V
Duty Cycle @ 40°C - Tig	160 amps @ 25%
	103 amps @ 60%
	80 amps @ 100%
Duty Cycle @ 40°C - Arc	140 amps @ 25%
	90 amps @ 60%
	70 amps @ 100%
Duty Cycle @ 20°C - Tig	160 amps @ 60%
	124 amps @ 100%
	140 amps @ 60%
Duty Cycle @ 20°C - Arc	140 amps @ 60%
	108 amps @ 100%
Insulation Class	H
Protection	IP21S

CONTENTS AND ACCESSORIES

HG1800P Tig/Arc Welder	Instruction Manual
4m WP17 Tig Torch	
2m Earth Cable with Earth Clamp	
Torch Consumable Accessory Set	
3m x 8mm Ø Gas Hose	



Note: If any of the above are missing or damaged, contact your distributor immediately.

GETTING TO KNOW YOUR WELDER

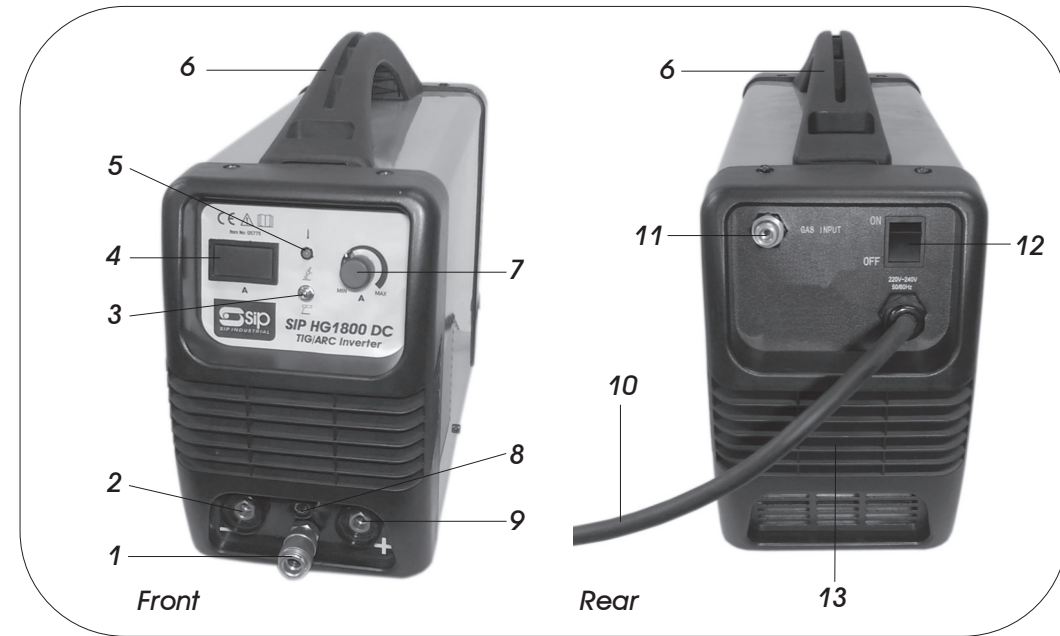

Ref.	Description	Ref.	Description
1.	Torch Gas Connection	8.	Torch Trigger Connection
2.	Negative Output Socket	9.	Positive Output Socket
3.	Arc / Tig mode selector	10.	Mains Lead
4.	Output Display	11.	Gas Connection
5.	Thermal Overload Indicator	12.	On/Off Switch
6.	Carry Handle	13.	Fan Inlet
7.	Output Control		