



Please dispose of packaging for the product in a responsible manner. It is suitable for recycling. Help to protect the environment, take the packaging to the local amenity tip and place into the appropriate recycling bin.



Never dispose of electrical equipment or batteries in with your domestic waste. If your supplier offers a disposal facility please use it or alternatively use a recognised re-cycling agent. This will allow the recycling of raw materials and help protect the environment.

**sip**  
SIP INDUSTRIAL

**machinery specialists since 1968**

## MIG Welder

T126, T136 & T166



05710, 05736, 05756

**FOR HELP OR ADVISE ON THIS PRODUCT PLEASE CONTACT YOUR DISTRIBUTOR, OR  
SIP DIRECTLY ON:  
TEL: 01509500400  
EMAIL: [sales@sip-group.com](mailto:sales@sip-group.com) or [technical@sip-group.com](mailto:technical@sip-group.com)  
[www.sip-group.com](http://www.sip-group.com)**

**Please read and fully understand the instructions in this manual before operation. Keep this manual safe for future reference.**

**Declaration of Conformity**

We

SIP (Industrial Products) Ltd  
Gelders Hall Road  
Shepshed  
Loughborough  
Leicestershire  
LE12 9NH  
England

As the manufacturer's authorised representative within the EC  
declare that the

Weldmate T126 Mig - SIP Part. No. 05710  
Weldmate T136 Mig - SIP Part. No. 05736  
Weldmate T166 Mig - SIP Part. No. 05756

**Conforms to the requirements of the following directive(s), as indicated.**

2006/95/EC	Low Voltage Directive
2004/108/EC	EMC Directive
89/686/EEC	Personal Protective Equipment Directive
2008/35/EC	RoHS Directive

**And the relevant harmonised standard(s), including**

EN 60794-1:2012  
EN 60794-10  
EN 379:2003  
EN 169:2002  
EN 175: 1997

Signed:  .....

Mr P. Ippaso - Managing Director - SIP (Industrial Products) Ltd  
Date: 02/06/2014.



## PARTS LIST WELDMATE MIG TORCH

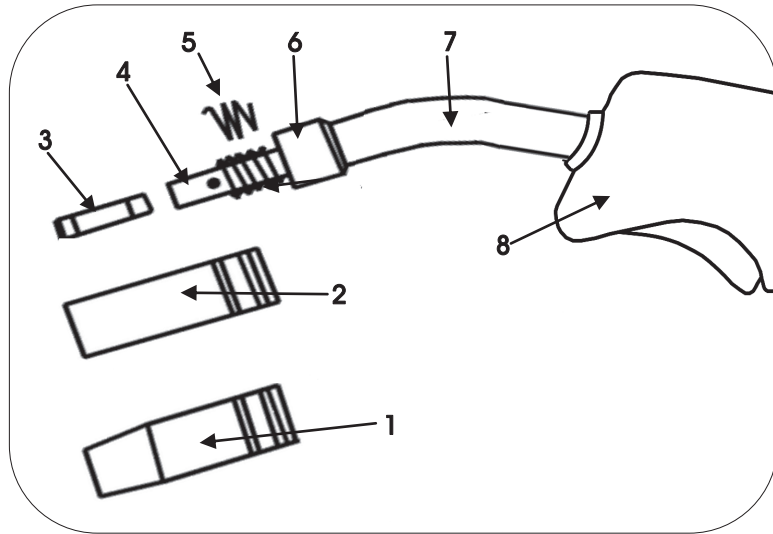

Ref. No.	Description	Sip Part No.	Ref. No.	Description	Sip Part No.
1.	Cylindrical Shroud	02684	5.	Shroud Spring	09084
2.	Conical Shroud	09086	6.	Insulator	WE02-00061
3.	Tip 0.6mm	09070	7.	Swan Neck	02712
3.	Tip 0.8mm	09080	8.	Handle set	WE02-00063
3.	Tip 0.9mm	09074	N/A	Gas valve	WE02-00062
4.	Gas diffuser	WE02-00060			

## CONTENTS

Page No.	Description
4.	Safety Symbols Used Throughout This Manual
4.	Safety Instructions
11.	Electrical Connection
12.	Guarantee
13.	Technical Specification
14.	Contents and Accessories
15.	Getting to Know Your MIG Welder
19.	Assembly Instructions
20.	Operating Instructions
23.	Maintenance
24.	Troubleshooting
25.	Wiring Diagram Weldmate T1 26 Mig
26.	Wiring Diagram Weldmate T1 36 Mig
27.	Wiring Diagram Weldmate T1 66 Mig
28.	Exploded Drawing Weldmate T1 26 Mig
29.	Parts List Weldmate T1 26 Mig
30.	Exploded Diagram Weldmate T1 36 Mig
31.	Parts List Weldmate T1 36 Mig
32.	Exploded Diagram Weldmate T1 66 Mig
33.	Parts List Weldmate T1 66 Mig
34.	MIG Torch Drawing and Parts List
35.	Declaration of Conformity

## SAFETY SYMBOLS USED THROUGHOUT THIS MANUAL



**Danger / Caution:** Indicates risk of personal injury and/or the possibility of damage.



**Warning:** Risk of electrical injury or damage!



**Note:** Supplementary information.

## SAFETY INSTRUCTIONS



**IMPORTANT:** Please read the following instructions carefully, *failure to do so could lead to serious personal injury and / or damage to the mig welder.*

When using your mig welder, basic safety precautions should always be followed to reduce the risk of personal injury and / or damage to the mig welder.

Read all of these instructions before operating the mig welder and save this user manual for future reference.

The mig welder should *not* be modified or used for any application other than that for which it was designed.

This mig welder was designed to supply electric current for MIG welding.

If you are unsure of its relative applications do not hesitate to contact us and we will be more than happy to advise you.

Before each use of the mig welder always check no parts are broken and that no parts are missing.

Always operate the mig welder safely and correctly.

**KNOW YOUR MIG WELDER:** Read and understand the owner's manual and labels affixed to the mig welder. Learn its applications and limitations, as well as the potential hazards specific to it.

**KEEP WORK AREA CLEAN AND WELL LIT:** Cluttered work benches and dark areas invite accidents. Floors must not be slippery due to oil, water or sawdust etc.

**DO NOT USE THE MIG WELDER IN DANGEROUS ENVIRONMENTS:** Do not use the mig welder in damp or wet locations, or expose it to rain. Provide adequate space surrounding the work area. Do not use in environments with a potentially explosive atmosphere.

**KEEP CHILDREN AND UNTRAINED PERSONNEL AWAY FROM THE WORK AREA:** All visitors

## PARTS LIST WELDMATE T166 MIG

Ref. No.	Description	Sip Part No.	Ref. No.	Description	Sip Part No.
1.	Left side panel	WE02-00035	21.	Fan support	WE02-00022
2.	Hinge	WE02-00051	22.	Fan motor	WE02-00023
3.	Lock	WE02-00002	23.	Fan Blade	WE02-00024
4.	Wire feed motor	WE02-00036	24.	Right side panel	WE02-00055
5.	Front panel	WE02-00003	25.	Handle	WE02-00015
6.	Rotary switch 6pos	WE02-00052	26.	Mains lead	WE02-00056
7.	On/Off switch	WE02-00004	27.	Rear panel	WE02-00057
8.	Thermal overload light	WE02-00053	28A.	Gas hose connector	WE02-00042
9.	Potentiometer knob	WE02-00007	28B.	Gas valve connector	WE02-00043
10.	Welding torch	02741	29.	Rectifier	WE02-00058
11.	Earth return lead	WE02-00010	30.	Rectifier support	WE02-00059
12.	Cable grommet	WE02-00009	31.	Breaker	WE02-00020
13.	Cable clamp	WE02-00011	32.	Auxiliary transformer	WE02-00031
14.	PCB holder	WE02-00013	33.	Centre panel	WE02-00046
15.	PCB	WE02-00037	34.	Positive terminal	WE02-00047
16.	Foot	WE02-00019	35.	Wire spool holder	WE02-00030
17.	Lower panel	WE02-00038	36.	Negative terminal	WE02-00048
18.	Mains filter	WE02-00016	37.	Fuse	WE02-00032
19.	Thermostat	WE01-00039	N/A.	Wire feed roller 0.6-0.8	WE02-00049
20.	Transformer c/w choke	WE02-00054			

## EXPLODED DIAGRAM WELDMATE T166 MIG

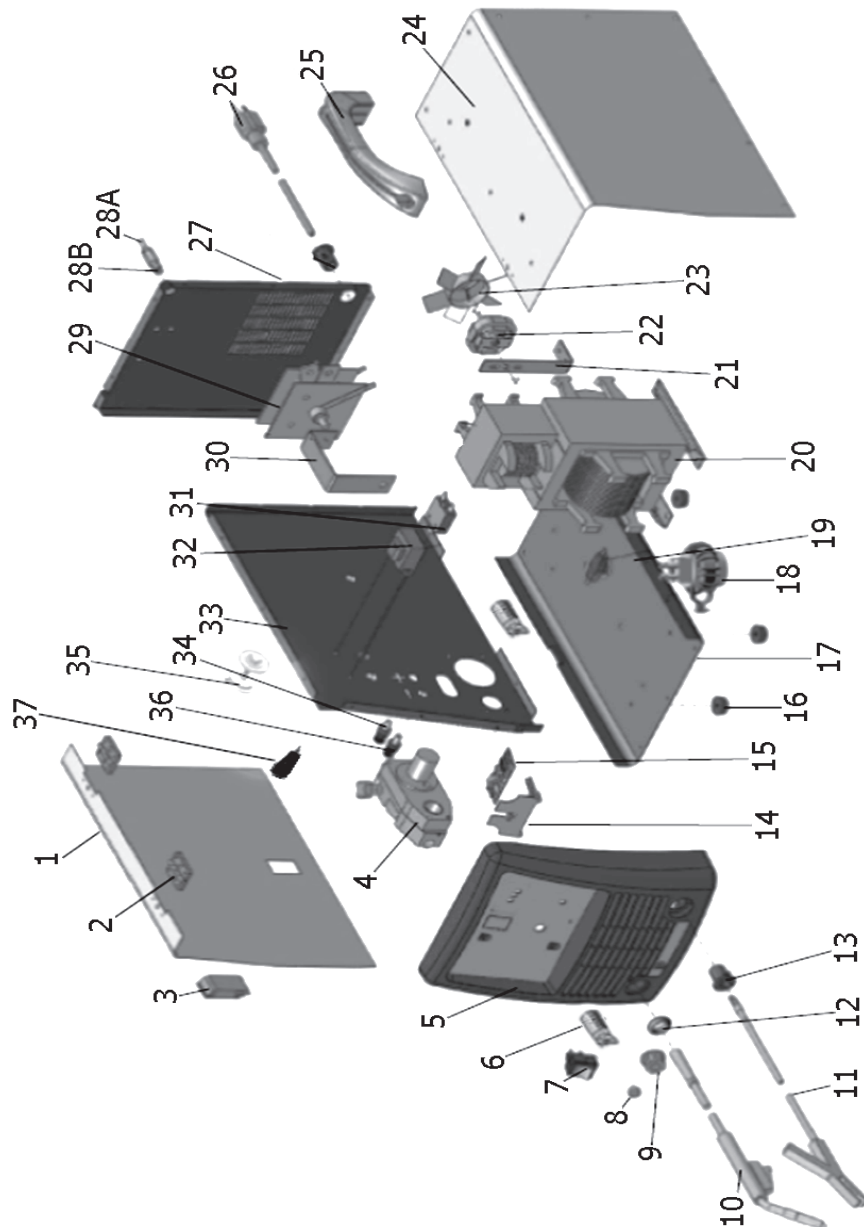

## SAFETY INSTRUCTIONS...cont

should be kept at a safe distance from the work area.

**STORE THE MIG WELDER SAFELY WHEN NOT IN USE:** The mig welder should be stored in a dry location and disconnected from the mains supply, and out of the reach of children.

**USE SAFETY CLOTHING / EQUIPMENT:** Use a CE approved welding mask at all times with the correct shade of filter lens. A fume extractor should be used particularly where there is little or no ventilation.

**PROTECT YOURSELF FROM ELECTRIC SHOCK:** When working with the mig welder, avoid contact with any earthed items (e.g. pipes, radiators, hobs and refrigerators, etc.). It is advisable wherever possible to use an RCD (residual current device) at the mains socket.

**STAY ALERT:** Always watch what you are doing and use common sense. Do not operate the mig welder when you are tired or under the influence of alcohol or drugs.

**DISCONNECT THE MIG WELDER FROM THE MAINS SUPPLY:** When not in use and before servicing.

**AVOID UNINTENTIONAL ARCING:** Make sure the switch is in the **OFF** position before connecting the mig welder to the mains supply.

**NEVER LEAVE THE MIG WELDER CONNECTED WHILST UNATTENDED:** Turn the mig welder off and disconnect it from the mains supply between jobs. Do not leave the mig welder connected to the mains supply if no more welding is to be done.

**DO NOT ABUSE THE MAINS LEAD:** Never attempt to move the mig welder by the mains lead or pull it to remove the plug from the mains socket. Keep the mains lead away from heat, oil and sharp edges. If the mains lead is damaged, it must be replaced by the manufacturer or its service agent or a similarly qualified person in order to avoid unwanted hazards. **All** extension cables must be checked at regular intervals and replaced if damaged.

**CHECK FOR DAMAGED PARTS:** Before every use of the mig welder, any damage found should be carefully checked to determine that it will operate correctly, safely and perform its intended function. Any damaged, split or missing parts that may affect its operation should be correctly repaired or replaced by an authorised service centre unless otherwise indicated in this instruction manual.

**KEEP ALL PANELS IN PLACE:** Never operate the mig welder with any panels removed, this is extremely dangerous.

**MAINTAIN THE MIG WELDER WITH CARE:** Keep the earth clamp and mig torch clean for the best and safest performance.

**USE ONLY RECOMMENDED ACCESSORIES:** Consult this user manual, your distributor or SIP directly for recommended accessories. Follow the instructions that accompany the accessories. The use of improper accessories may cause hazards and will invalidate any warranty you may have.

**SECURE THE WORK-PIECE:** Always use welding clamps to secure the work piece. This frees up both hands to operate the mig welder correctly.

**DO NOT OVERREACH:** Keep proper footing and balance at all times.

**USE THE RIGHT TOOL:** Do not use the mig welder to do a job for which it was not de-

## SAFETY INSTRUCTIONS....cont

signed.

**DO NOT OPERATE THE MIG WELDER IN EXPLOSIVE ATMOSPHERES:** Do not use the mig welder in the presence of flammable liquids, gases, dust or other combustible sources. Mig welding will create sparks which can ignite the dust or fumes.

**DO NOT EXPOSE THE MIG WELDER TO RAIN OR USE IT IN WET CONDITIONS:** Water entering the mig welder will greatly increase the risk of electric shock.

**HAVE YOUR MIG WELDER REPAIRED BY A QUALIFIED PERSON:** The mig welder is in accordance with the relevant safety requirements. Repairs should only be carried out by qualified persons using original spare parts, otherwise this may result in considerable danger to the user.

- Stop operation immediately if you notice anything abnormal.
- Always disconnect the plug from the mains supply before cleaning or servicing etc.
- Be alert at all times, especially during repetitive, monotonous operations; Don't be lulled into a false sense of security.
- Use of improper accessories may cause damage to the mig welder and surrounding area as well as increasing the risk of injury.
- Do not modify the mig welder to do tasks other than those intended.
- To avoid injury, the work-piece should never be held with the bare hands.
- Appropriate personal protective equipment **MUST** be worn and **MUST** be designed to protect against all hazards created. Severe permanent injury can result from using inappropriate or insufficient protective equipment - Eyes in particular are at risk.
- The work must be clamped firmly whilst welding, If its loose it could result in personal injury, damage to the machine or to the item that is being welded.
- **DO NOT** attempt any repairs unless you are a competent electrician or engineer.
- Ensure that the machine is connected to the correct supply voltage and protected by a fuse or circuit breaker of the recommend rating.

## PARTS LIST WELDMATE T136 MIG

Ref. No.	Description	Slp Part No.	Ref. No.	Description	Slp Part No.
1.	Left side panel	WE02-00035	21.	Fan support	WE02-00022
2.	Hinge	WE02-00029	22.	Fan motor	WE02-00023
3.	Lock	WE02-00002	23.	Fan Blade	WE02-00024
4.	Wire feed motor	WE02-00036	24.	Right side panel	WE02-00040
5.	Front panel	WE02-00003	25.	Handle	WE02-00015
6.	Rocker switch	WE02-00005	26.	Mains lead	WE02-00027
7.	On/Off switch	WE02-00004	27.	Rear panel	WE02-00041
8.	Thermal overload light	WE02-00006	28A.	Gas hose connector	WE02-00042
9.	Potentiometer knob	WE02-00007	28B.	Gas valve connector	WE02-00043
10.	Welding torch	02741	29.	Rectifier	WE02-00044
11.	Earth return lead	WE02-00010	30.	Rectifier support	WE02-00045
12.	Cable grommet	WE02-00009	31.	Breaker	WE02-00020
13.	Cable clamp	WE02-00011	32.	Auxiliary transformer	WE02-00031
14.	PCB holder	WE02-00013	33.	Centre panel	WE02-00046
15.	PCB	WE02-00037	34.	Positive terminal	WE02-00047
16.	Foot	WE02-00019	35.	Wire spool holder	WE02-00030
17.	Lower panel	WE02-00038	36.	Negative terminal	WE02-00048
18.	Mains filter	WE02-00016	37.	Fuse	WE02-00032
19.	Thermostat	WE01-00039	N/A.	Wire feed roller 0.6-0.8	WE02-00049
20.	Transformer c/w choke	WE02-00040			

## EXPLODED DIAGRAM WELDMATE T136 MIG

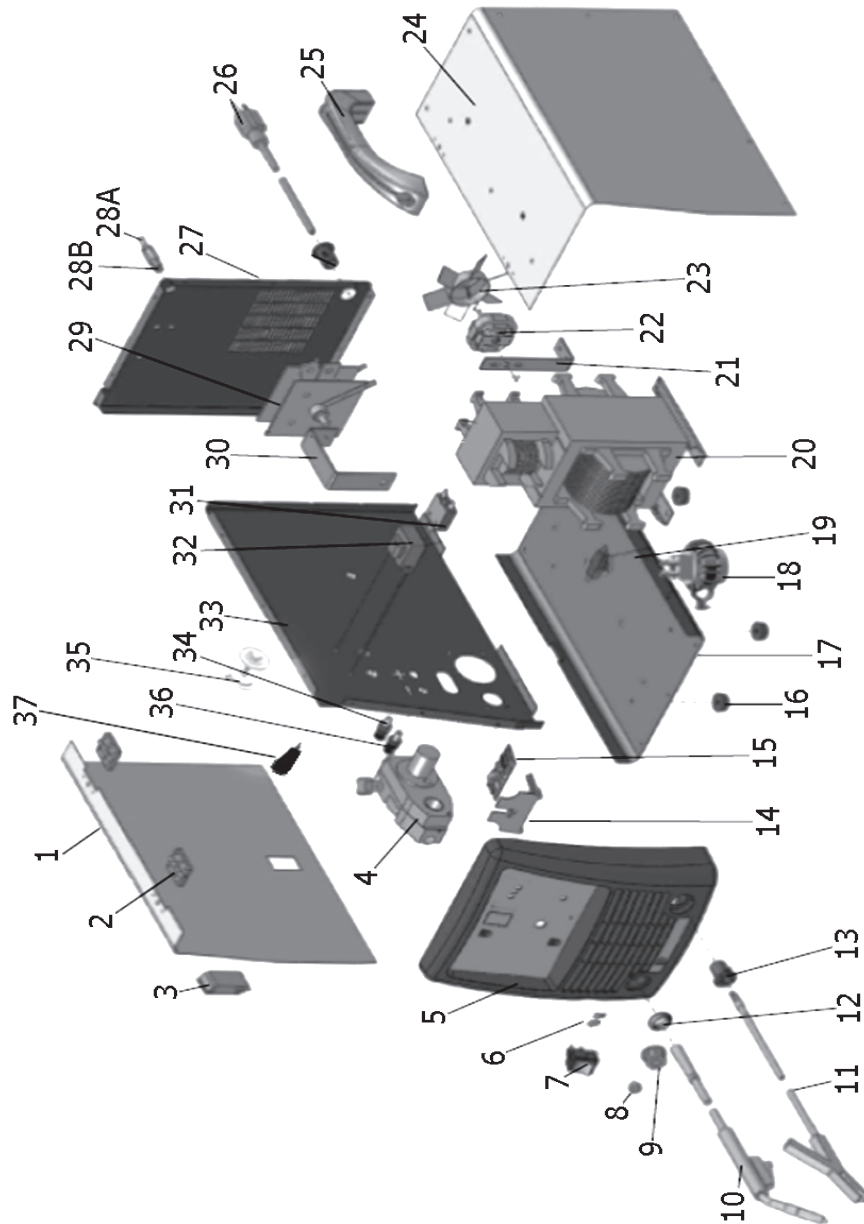

## SAFETY INSTRUCTIONS...cont

### ELECTRIC SHOCK

- Keep your body and clothing dry. Never work in a damp area without adequate insulation against electrical shock, stay on a dry duck board, or rubber mat when dampness or sweat can not be avoided. Sweat, sea water or moisture between the body and an electrically HOT part or grounded metal reduces the body surface electrical resistance enabling dangerous and possibly lethal currents to flow through the body.
- **NEVER** allow live metal parts to touch bare skin or any wet clothing, be sure welding gloves are dry.
- Before welding, check for continuity; Be sure the earth clamp is connected to the work piece as close to the welding areas as possible. Grounds connected to building frame work or other remote locations from the welding area reduce efficiency and increase the potential electric shock hazard. Avoid the possibility of the welding current passing through lifting chains, crane cables or various electric paths.
- Frequently inspect leads for wear, splits, cracks and any other damage. **IMMEDIATELY** replace those with worn or damaged insulation to avoid a possibly lethal shock from bare leads.

### FIRE

- All inflammable materials must be removed from the area.
- Have a suitable fire extinguisher available close by.
- Causes of fire and explosion are; combustibles reached by the arc, flame, flying sparks, hot slag or heated material, misuse of compressed gases and cylinders and short circuits.
- Flying sparks or falling slag can pass through cracks along pipes, through windows or doors and through walls or floor openings and out of sight of the operator. Sparks and slag can fly up-to 10 metres.
- Keep equipment clean and operable; Free of oil, grease and of metallic particles (in electrical parts) that can cause short circuits.
- If combustibles are in the area **DO NOT** weld; Move the work, if practical to an area free of combustibles. Avoid paint spray rooms, dip tanks, storage areas and ventilators. If the work can not be moved then move the combustibles at least 10 metres away and out of the reach of sparks and heat, or protect against ignition with suitable and snug fitting fire resistant covers or shields.
- Walls touching combustibles on opposite sides should not be welded on, walls, ceilings and the floor near the work area should be protected by heat resistant covers or shields.
- Openings (concealed or visible) in floors or walls within 10 metres may expose combustibles to sparks.
- Combustibles adjacent to walls, ceilings, roofs or metal partitions can be ignit-

## SAFETY INSTRUCTIONS...cont

ed by radiant or conducted heat.

- After the work is done, check that the area is free of sparks, glowing embers and flames.
- An empty container that has held combustibles, or that can produce flammable or toxic vapours when heated, must never be welded, unless the container has first been cleaned. Consult HSE INDG214, HSG250 and CS15. HSE document CS15 includes information on cleaning by thorough steam or solvent/caustic cleaning followed by purging and inserting with nitrogen, carbon dioxide or water filling just below working level.
- A container with unknown contents should be treated as if it contained combustibles (see previous paragraph), **DO NOT** depend on sense of smell or sight to determine if it is safe to weld.
- Hollow items must be vented before welding as they can explode.
- Explosive atmosphere; Never weld when the air may contain flammable dust, gas or liquid vapours (such as petrol).

## GLARE AND BURNS

- The electric welding arc must not be observed with the naked eye. Always use the welding mask, ensure the welding mask is fitted with the correct shade of filter lens for the welding current level.
- Welding gauntlet gloves should be worn to protect the hands from burns, non-synthetic overalls with buttons at the neck and wrist, or similar clothing should be worn. Greasy overalls should not be worn. Wear suitable protective footwear.
- Wear protective clothing, welding gauntlet gloves, hat and high safety toe shoes.
- Avoid oily or greasy clothing, a spark may ignite them.
- Hot metal such as electrode stubs and work pieces should never be handled without gloves.
- First aid facilities and a qualified first aid person should be available for each shift unless medical facilities are close by for immediate treatment of flash burns to the eyes and skin.
- Flammable hair products should not be used by persons intending to weld.
- Warn bystanders not to watch the arc and not to expose themselves to the welding-arc rays or to hot metal.
- Keep children away whilst welding, they are not aware that looking at an arc can cause serious eye damage.
- Protect other nearby personnel from arc rays and hot sparks with a suitable non-flammable partition.

## PARTS LIST WELDMATE T126 MIG

Ref. No.	Description	Sip Part No.	Ref. No.	Description	Sip Part No.
1.	Left side panel	WE02-00001	18.	Thermostat	WE02-00018
2.	Lock	WE02-00002	19.	Foot	WE02-00019
3.	Plastic panel	WE02-00003	20.	Circuit breaker 25A	WE02-00020
4.	On/Off switch	WE02-00004	21.	Middle panel	WE02-00021
5.	Rocker switch	WE02-00005	22.	Fan support plate	WE02-00022
6.	Thermal overload light	WE02-00006	23.	Fan motor	WE02-00023
7.	Potentiometer knob	WE02-00007	24.	Fan Blade	WE02-00024
8.	Welding torch	02741	25.	Right side panel	WE02-00025
9.	Grommet	WE02-00009	26.	Cable holder	WE02-00026
10.	Earth return lead c/w clamp	WE02-00010	27.	Mains lead	WE02-00027
11.	Cable holder	WE02-00011	28.	Rear panel	WE02-00028
12.	Bottom panel	WE02-00012	29.	Hinge	WE02-00029
13.	PCB holder	WE02-00013	30.	Wire spool holder	WE02-00030
14.	PCB	WE02-00014	31.	Auxiliary transformer	WE02-00031
15.	Handle	WE02-00015	32.	Fuse 6.3A	WE02-00032
16.	Mains filter	WE02-00016	33.	Wire feed motor	WE02-00033
17.	Transformer	WE02-00017	N/A.	Wire feed roller	WE02-00034



## EXPLODED DIAGRAM WELDMATE T126 MIG

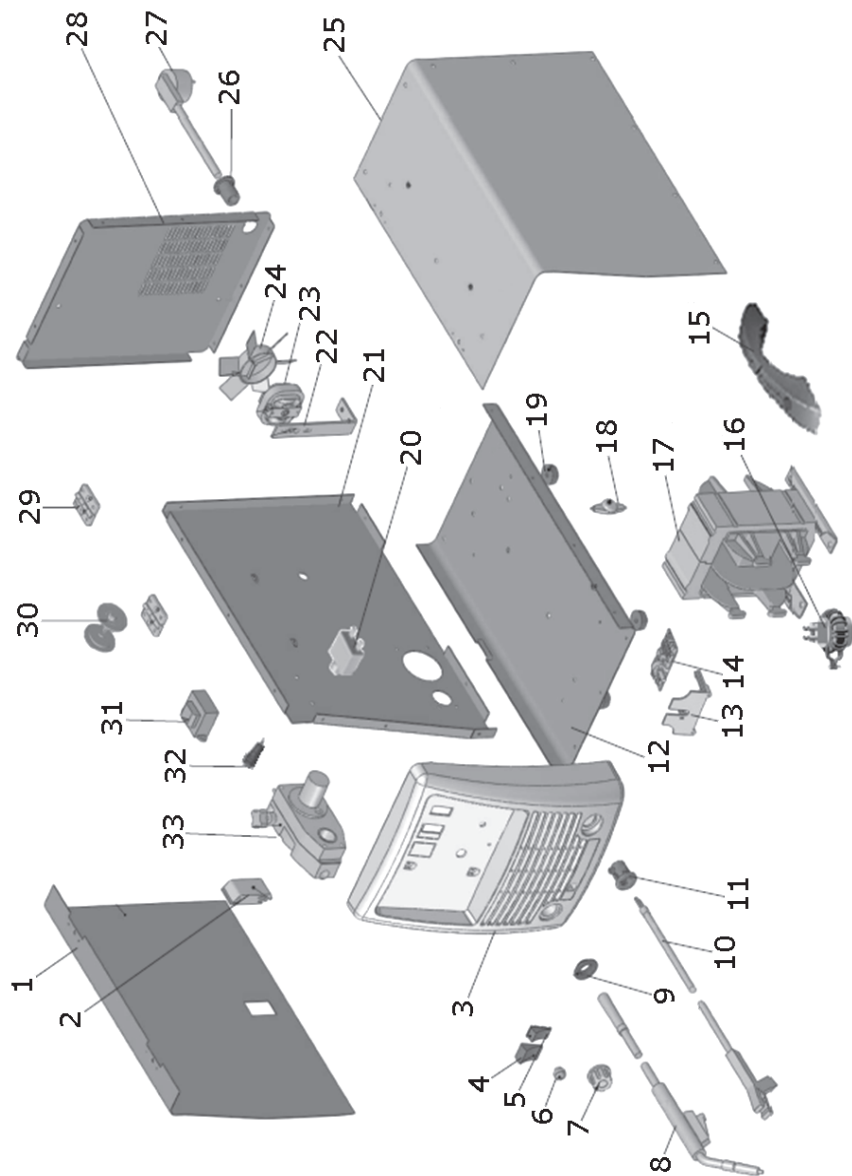

## SAFETY INSTRUCTIONS...cont

### VENTILATION

- Ventilation must be adequate to remove the smoke and fumes during welding (see the relevant safety standard for acceptable levels).
- Toxic gases may be given off when welding, especially if zinc or cadmium coated materials are involved, welding should be carried out in a well ventilated area and the operator should always be alert to fume build-up.
- Areas with little or no ventilation should always use a fume extractor.
- Vapours of chlorinated solvents can form the toxic gas phosgene when exposed to U.V radiation from an electric arc. All solvents, degreasers and potential sources of these vapours must be removed from the arc area.
- Severe discomfort, illness or death can result from fumes, vapours, heat, oxygen enrichment or depletion that welding (or cutting) may produce. This will be prevented by adequate ventilation or using a fume extractor. **NEVER** ventilate with oxygen.
- Lead, cadmium, zinc, mercury, beryllium bearing and similar materials when welded may produce harmful concentrations of toxic fumes. Adequate ventilation must be provided for every person in the area. The operator should also wear an air supplied respirator, for beryllium both must be used.
- Metals coated with or containing materials that emit toxic fumes should not be heated unless coating is removed from the work surface. The area should be well ventilated or the operator should wear an air supplied respirator.
- Work in a confined space only while it is being ventilated and if necessary whilst wearing an air supplied respirator.
- Gas leaks in a confined space should be avoided, leaking gas in large quantities can change oxygen concentration dangerously. **DO NOT** bring gas cylinders into a confined space.
- Leaving a confined space you must shut off the gas supply at the source to prevent possible accumulation of gases in the space if down stream valves are left open. Check to be sure that the space is safe before re entering it.
- Vapours from chlorinated solvents can be decomposed by the heat of the arc (or flame) to form phosgene a highly toxic gas and other lung and eye-irritating products. The ultra violet (radiant) energy of the arc can also decompose trichloroethylene and perchlorethylene vapours to form phosgene. **DO NOT WELD** or cut where solvent vapours can be drawn into the welding atmosphere, or where the radiant energy can penetrate to atmospheres containing even minute amounts of trichloroethylene or perchlorethylene.

## SAFETY INSTRUCTIONS....cont



When using the mig welder always ensure the operator as well as those in the area use a welding mask with the correct shade filter lens.



Some metals and metal composites have the potential to be highly toxic; always wear a face mask .



**CAUTION:** The warnings and cautions mentioned in this user manual can not cover all possible conditions and situations that may occur. It must be understood by the operator that common sense and caution are factors which cannot be built into this product, but must be applied.

## WIRING DIAGRAM WELDMATE T166 MIG

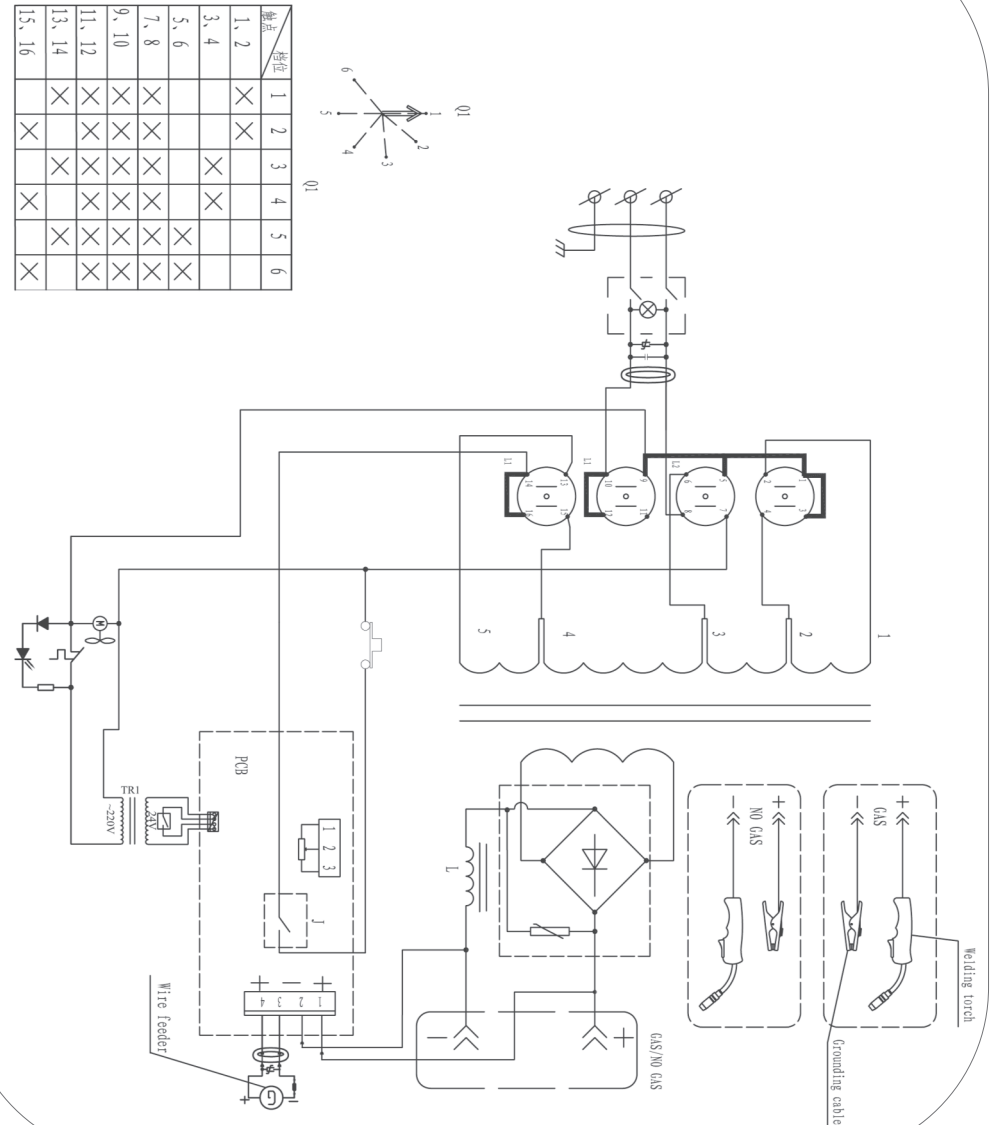

## WIRING DIAGRAM WELDMATE T136 MIG

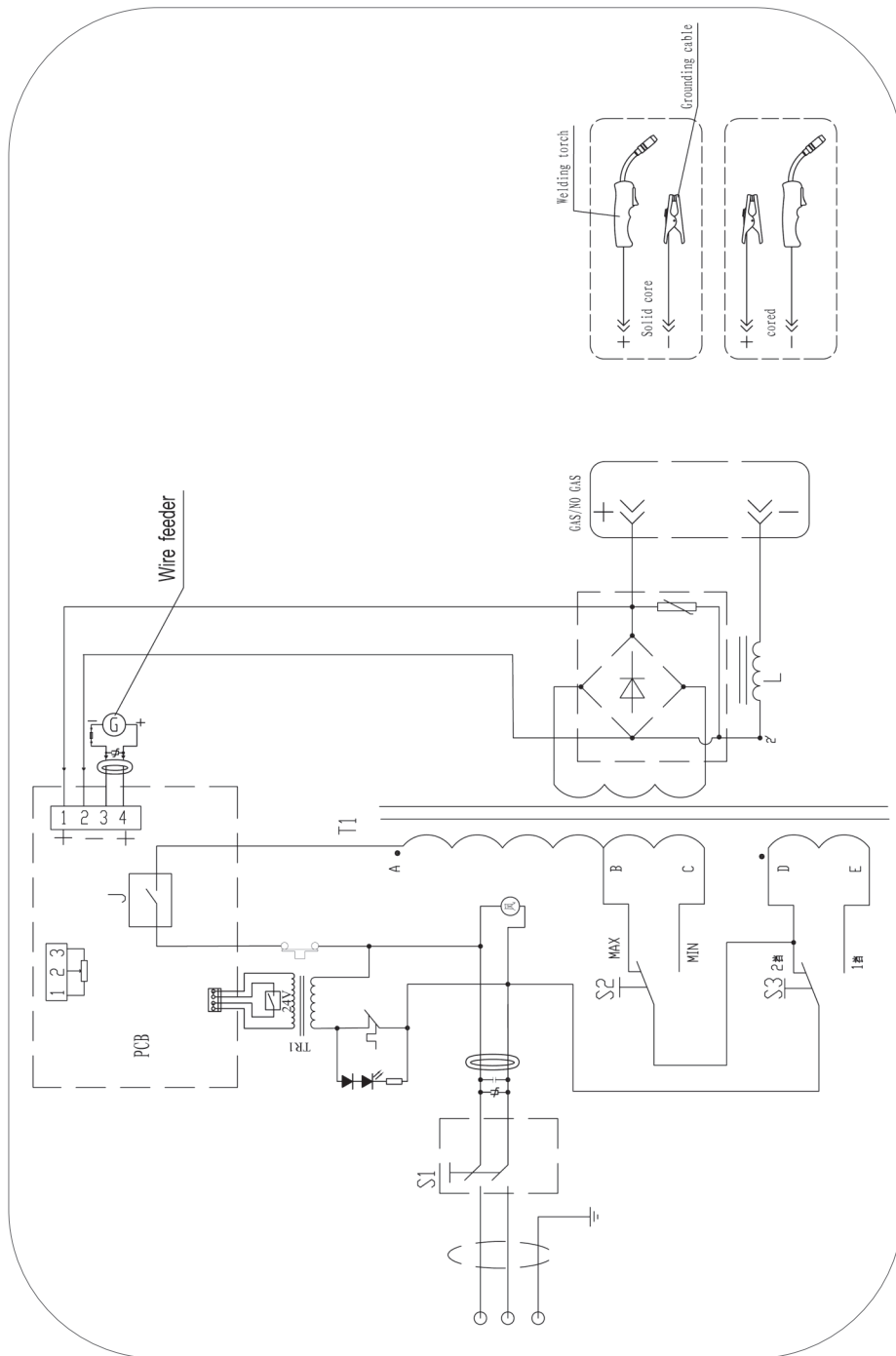

## ELECTRICAL CONNECTION

**WARNING!** It is the responsibility of the owner and the operator to read, understand and comply with the following:

You must check all electrical products, before use, to ensure that they are safe. You must inspect power cables, plugs, sockets and any other connectors for wear or damage.

You must ensure that the risk of electric shock is minimised by the installation of appropriate safety devices; A residual current circuit Breaker (RCCB) should be incorporated in the main distribution board. We also recommend that a residual current device (RCD) is used. It is particularly important to use an RCD with portable products that are plugged into a supply which is not protected by an RCCB. If in any doubt consult a qualified electrician.

### Connecting to the power supply:

The T126 and T136 are supplied with a 13A plug pre-fitted.

The T166 is supplied without a plug fitted, it must not be connected a 13A supply, consult the technical specification table (page 13) for the required rating, if in doubt contact a qualified electrician. Before using the welder, inspect the all the leads and plugs to ensure that non are damaged. If any damage is visible have the welder inspected / repaired by a suitably qualified person.

### The wires for the plug are coloured in the following way:

Yellow / green	Earth
Blue	Neutral
Brown	Live

As the colours of the wires may not correspond with the markings in your plug, proceed as follows:

The wire which is coloured brown, must be connected to the terminal, which is marked L or coloured red.

The wire which is coloured blue, must be connected to the terminal marked with N or coloured black.

The wire which is coloured yellow / green should be connected to the terminal which is coloured the same or marked with this symbol

Always secure the wires in the plug terminal carefully and tightly. Secure the cable in the cord grip carefully.

## ELECTRICAL CONNECTION....cont



**Warning:** Never connect live or neutral wires to the earth terminal of the plug. Only fit an approved plug with the correct rated fuse. If in doubt consult a qualified electrician.



**Note:** Always make sure the mains supply is of the correct voltage and the correct fuse protection is used. In the event of replacing the fuse always replace the fuse with the same value as the original.



**Note:** If an extension lead is required in order to reach the mains supply; ensure that this too is rated for the correct voltage and fuse rating.

## GUARANTEE

### Guarantee:

This SIP MIG welder is covered by a 12 month parts and labour warranty covering failure due to manufacturers defects. This does not cover failure due to misuse or operating the MIG welder outside the scope of this manual - any claims deemed to be outside the scope of the warranty may be subject to charges including, but not limited to parts, labour and carriage costs.

Failure to regularly clean your MIG welder will shorten its working life and reduce performance. The warranty does not cover consumable items such as tips, shrouds, clamps, etc.



**Note:** Proof of purchase will be required before any warranty can be honoured.

## WIRING DIAGRAM WELDMATE T126 MIG

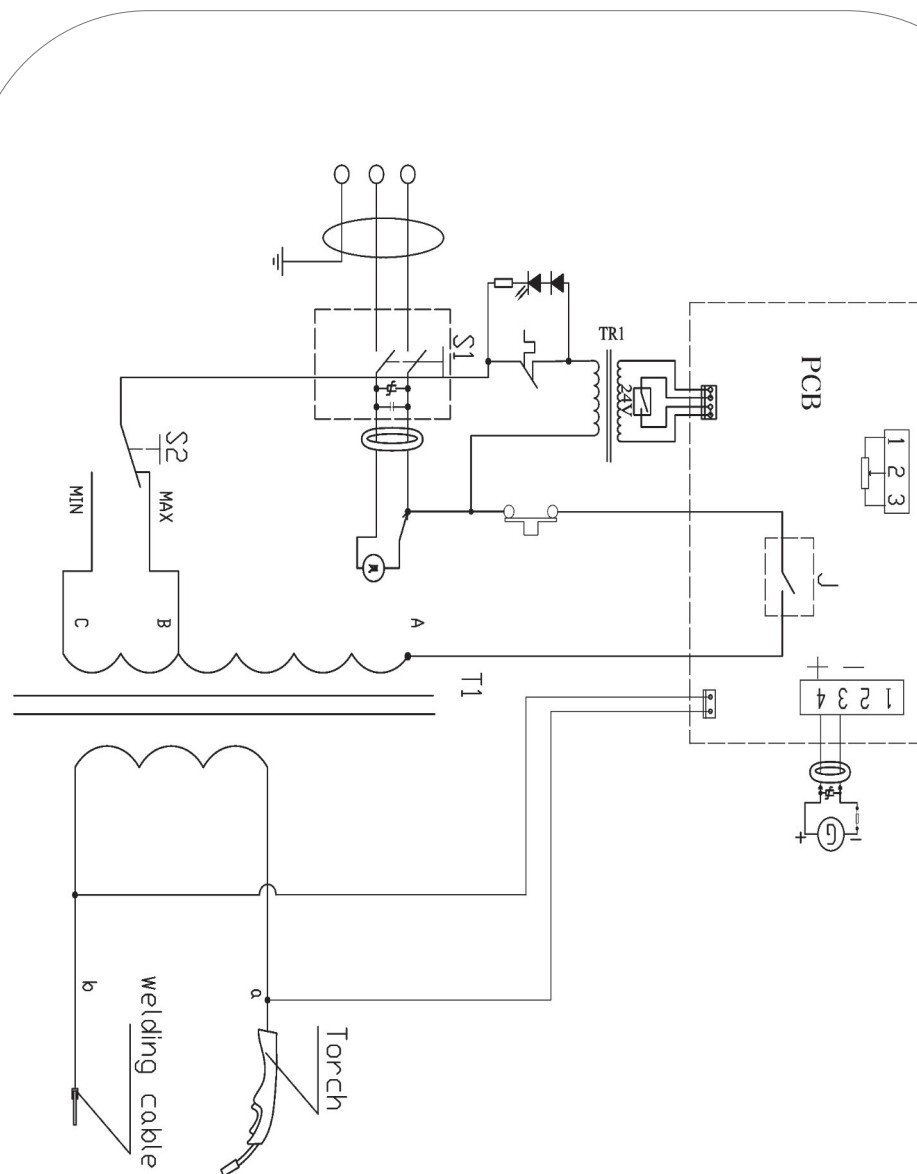

## TROUBLESHOOTING

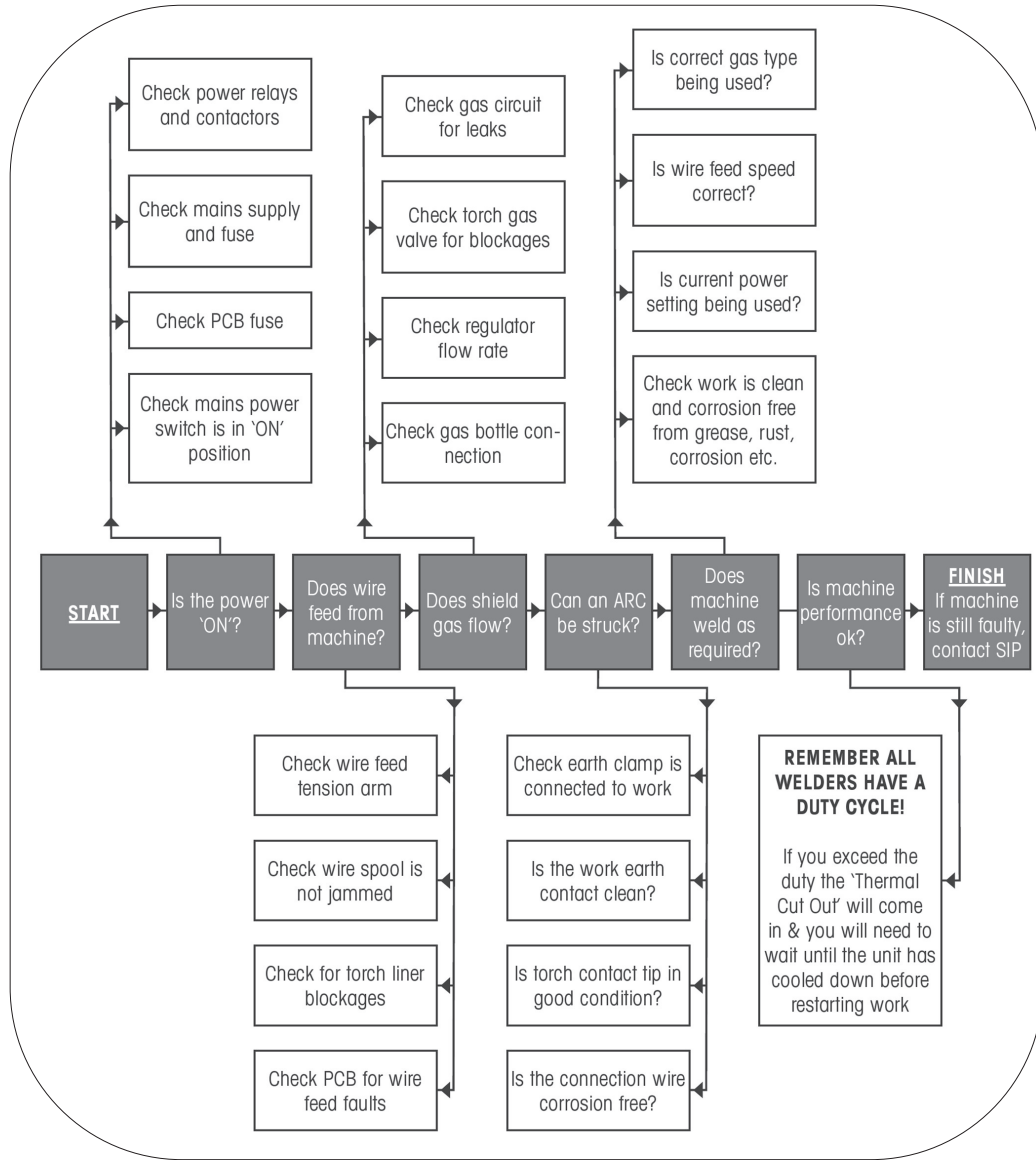

## TECHNICAL SPECIFICATION

Model	Weldmate T126 (Gasless)	Weldmate T136 (Gas / Gasless)	Weldmate T166 (Gas / Gasless)
Input Voltage	230v ~ 50Hz	230v ~ 50Hz	230v ~ 50Hz
Input Current	13 amps	13 amps	16 amps
Maximum OCV	31V (AC)	30V (DC)	32V (DC)
Output Current (Amps)	60 - 125 (Peak)	30 - 135 (Peak)	30 - 165 (Peak)
Output Voltage	17v - 18.5v	15.5v - 18v	15.5v - 19.25v
Wire Diameter	0.8mm - 0.9mm	0.6mm - 0.8mm	0.6mm - 0.8mm
Wire Spool Size	0.7kg - 5kg	0.7kg - 5kg	0.7kg - 5kg
Wire Type	Flux cored	Solid / Flux cored	Solid / Flux cored
Weld Thickness	1.2mm - 4.0mm	0.7mm - 5.4mm	0.7mm - 6.2mm
Maximum Wire Speed	14m/min	16m/min	16m/min
Weld Material	Mild steel	Mild steel, Stainless steel, Aluminium	Mild steel, Stainless steel, Aluminium
Duty Cycle	90 amps @ 20%	80 amps @ 20%	105 amps @ 20%
	60 amps @ 60%	46 amps @ 60%	60 amps @ 60%
	-	-	47 amps @ 100%
Power Settings	2	4	6
Insulation Class	H	H	H
Protection	IP21S	IP21S	IP21S
Net Weight	16Kg	20Kg	25.8Kg



**Note:** Only the Weldmate T126 & T136 can be operated from a 13A supply, using the Weldmate T166 from a 13A supply will invalidate the warranty.



**Note:** If none of the above solutions work then contact your local distributor for repair, or contact SIP technical for more advise.

## CONTENTS AND ACCESSORIES

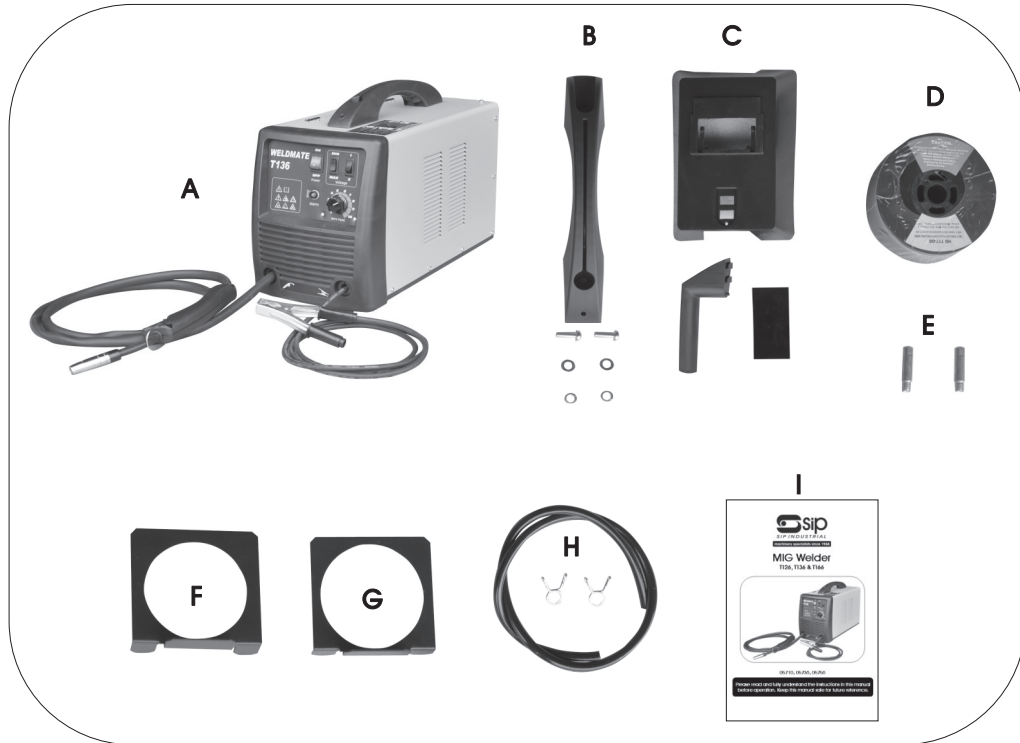

Ref. No.	Description
A.	MIG Welder
B.	Handle & Fixings
C.	Face Mask
D.	Gasless Wire
E	Mig Tips
F.	Bottle Bracket (69mm T136 and T166 only)
G.	Bottle Bracket (74mm T136 and T166 only)
H.	Gas Hose And Clips (T136 and T166 only)
I.	Manual



**Note:** If any of the above are missing or damaged, contact your distributor immediately.

## MAINTENANCE

- If the fault light illuminates you should contact your distributor, or SIP directly to have the welder checked / repaired.
- Clear dust from the machine at regular intervals, if used in a dirty environment the machine should be cleaned once a month.
- Check all connections are clean and tight, if there is any oxidization clean the connection with a mild abrasive or wire brush.
- Check all cable for damaged or degradation to the insulation, replace if any found.
- Check earth clamp condition ensure they clamp tightly, replace if damaged or loose.
- If the machine is not to be used for a long time, store it in the original packing a dry place.
- The mig tip and shroud must be cleaned frequently to removes spatter.
- Replace the mig tip regularly, good electrical contact between the tip and wire is essential.
- The torch liner should be blown through with dry compressed air from time to time, if the wire does not pass freely through the liner it should be replaced.

## OPERATING INSTRUCTIONS...cont

- Switch the welder on.
- Hold the torch out straight and press the torch trigger until the wire passes out of the end of the torch.
- Refit the MIG tip and shroud.
- Adjust the pressure adjustment knob so the wire feeds smoothly but not so much that the wire is crushed.

### PREPARATION FOR WELDING

- Clean the area to be welded, and the earthing point of all rust, paint and contaminants etc.
- Place the earth clamp on to a cleaned area of the work piece.
- Connect the welder to the electrical supply but do not switch on.

### WELDING

- Fit the correct size tip to match your wire & wire feed roller.
- Set the voltage and wire speed by turning the appropriate controls.
- Switch the welder on.
- Press the torch trigger and feed the wire out slightly.
- Cut the wire about 3mm from the end of the mig tip.
- Turn on the gas supply (T136 & T166 only).



**Note:** If using solid wire check the gas is the correct type and the gas regulator (not supplied) is turned on.

- Position the torch so the mig tip is about 6mm from the point where the welding is to commence.
- Press the torch trigger and the wire will feed, move the torch slowly in the chosen direction.
- Once the weld is completed, release the torch trigger.
- For future reference make a note the voltage and wire speed setting material that has been welded.



**Note:** It is advisable to check the correct settings on a scrap piece of metal which is the same as the one to be welded.



**Note:** If the arc has a humming sound and a blob forms on the end of the mig tip then you have insufficient wire speed and it should be increased. If the arc has an erratic sound, and the torch feels that the wire is hitting against the work then the wire speed is too high. When the wire speed is correct you should get a steady crackling sound.

## GETTING TO KNOW YOUR WELDER

### WELDMATE T126 MIG

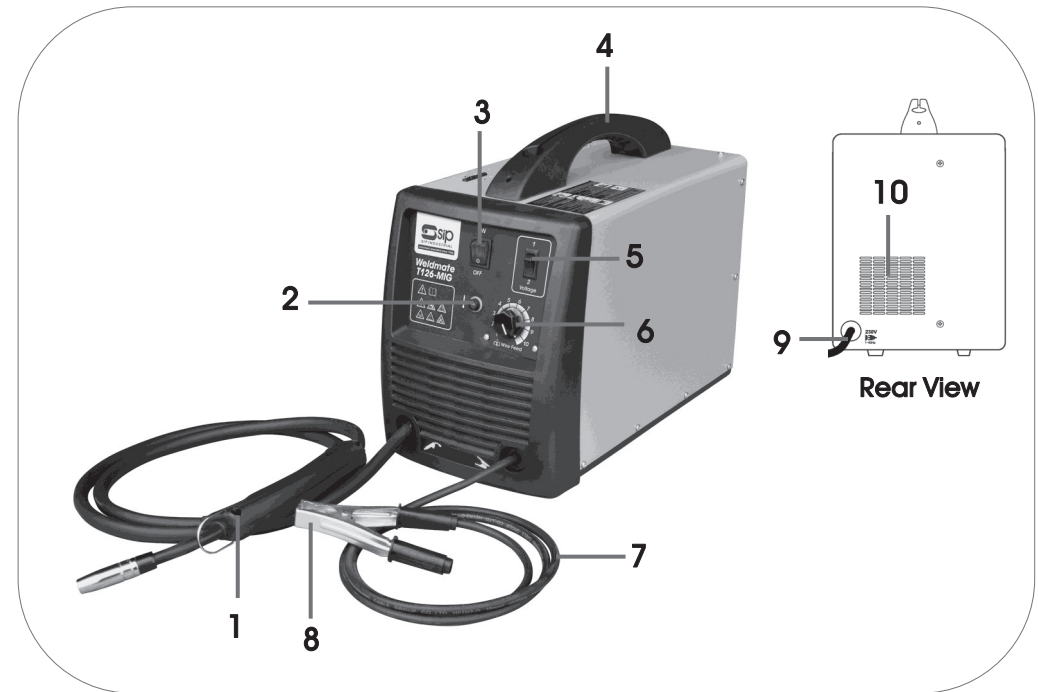

Ref. No.	Description	Ref. No.	Description
1.	Welding Torch	6.	Wire Speed Control
2.	Thermal Overload Indicator	7.	Earth Return Lead
3.	Power Switch	8.	Earth Clamp
4.	Handle	9.	Mains Lead
5.	Output Selector Switch	10.	Fan Grill

## GETTING TO KNOW YOUR WELDER....cont

### WELDMATE T136 MIG

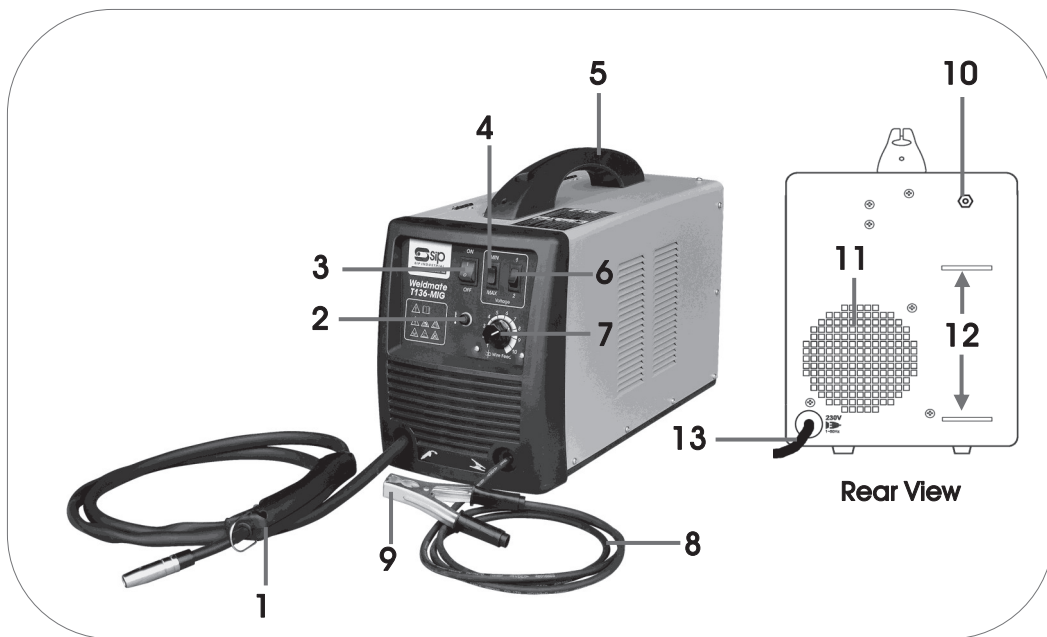

Ref. No.	Description	Ref. No.	Description
1.	Welding Torch	8.	Earth Return Lead
2.	Thermal Overload Indicator	9.	Earth Clamp
3.	Power Switch	10.	Gas Hose Fitting
4.	Coarse Output Selector Switch	11.	Fan Grill
5.	Handle	12.	Bottle Bracket Slots
6.	Fine Output Selector Switch	13.	Mains Lead
7.	Wire Speed Control		

## OPERATING INSTRUCTIONS....cont

The Weldmate T136 has 4 power settings (see below diagram).

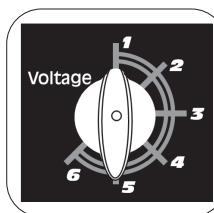
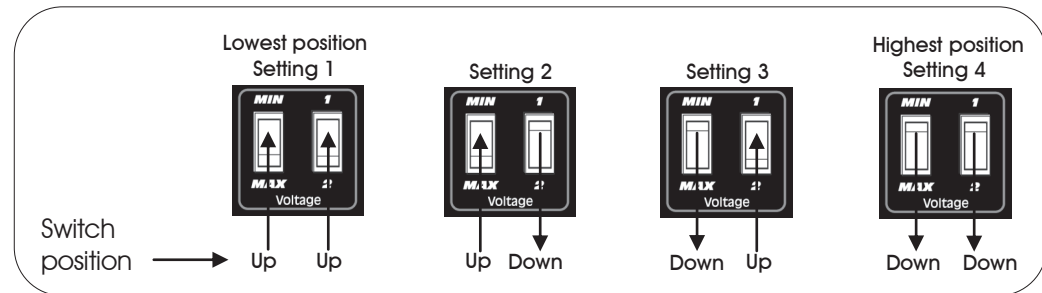

The Weldmate T166 has 6 power settings, lowest setting is 1 and the highest is 6 (see left diagram).

### FITTING AND FEEDING THE WIRE

- Fit the wire spool onto the spool holder - if using a 5kg reel ensure it is correctly seated - Secure in place by tightening the nut.



**Note:** The wire should always feed from the bottom of the reel.

- Check the wire feed roller matches the wire size; If not remove the roller cover by rotating it by a ¼ of a turn anti-clockwise, turn the roller over, and refit the cover.
- Connect the welder to a suitable electrical supply, but do not switch on.
- Remove the shroud from the torch by rotating the shroud clockwise and pulling at the same time.
- Remove the MIG tip.
- Pull the pressure adjustment knob so it pivots off the tension arm.
- Remove the free end of the MIG wire from the side of the wire spool, trim the distorted end of the wire with a pair of wire cutters; Hold the wire carefully as it will try to unwind from the spool.
- Lift the tension arm.
- Pass the wire through the inlet guide, through the wire feed roller groove and then in to the torch liner.
- Lower the tension arm and pivot the pressure adjustment knob up and back on to the tension arm.



## OPERATING INSTRUCTIONS

### GAS SELECTION (T136 & T166)

Material	Gas To Use
Mild Steel	Argon / CO <sup>2</sup> Mix or CO <sup>2</sup>
Stainless Steel	Argon / O <sup>2</sup> Mix
Aluminium	Argon



**Note:** The Weldmate T126 Mig is a gasless machine and does not require gas.



**Note:** In order to use gas you will need to purchase a gas bottle and a regulator, disposable gas cylinders all use the same regulator. Refillable gas bottles Argon, Argon CO<sub>2</sub> and Argon O<sub>2</sub> use the same regulator with a male thread, CO<sub>2</sub> uses a different regulator.

### SETTING THE POLARITY (T136 & T166)

The polarity of the welding torch and earth return lead is based on the wire type to be used, see table below.

Metal Type	Wire Type	Link Lead	Earth Lead	Gas
Steel	Solid	+	-	CO <sub>2</sub> or Argon CO <sub>2</sub>
Steel	Gasless Flux core	-	+	None
Stainless Steel	Solid	+	-	Argon o <sub>2</sub>
Aluminium	Solid	+	-	Argon

### POWER SETTINGS

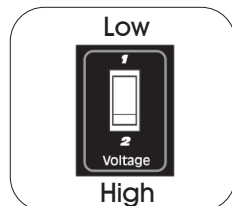

The Weldmate T126 has 2 power settings (see left diagram).

## GETTING TO KNOW YOUR WELDER...cont

### WELDMATE T166 MIG

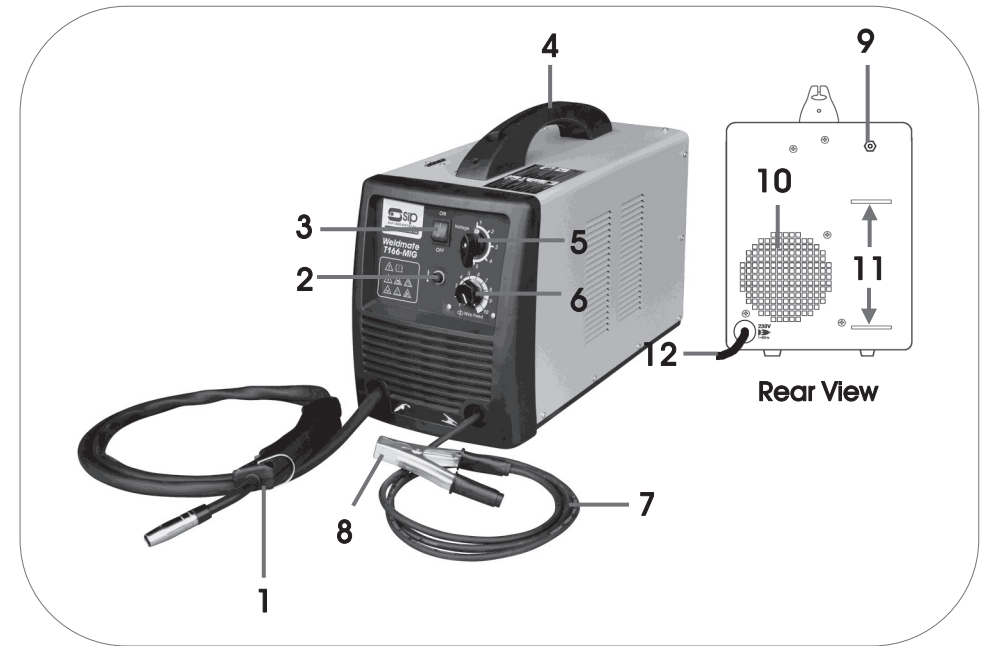

Ref. No.	Description	Ref. No.	Description
1.	Welding Torch	7.	Earth Return Lead
2.	Thermal Overload Indicator	8.	Earth Clamp
3.	Power Switch	9.	Gas Hose Fitting
4.	Handle	10.	Fan Grill
5.	Output Selector Switch	11.	Bottle Bracket Slots
6.	Wire Speed Control	12.	Mains Lead

## GETTING TO KNOW YOUR WELDER...cont

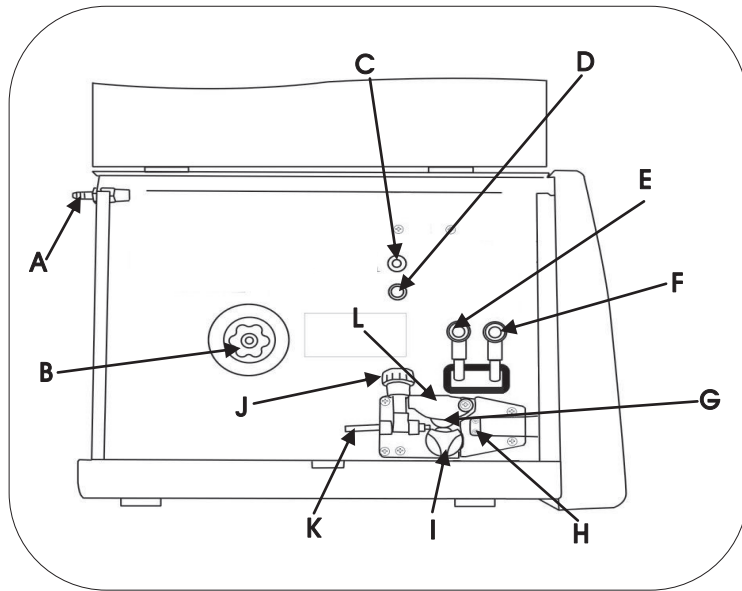

Ref. No.	Description	Ref. No.	Description
A.	Gas Hose Fitting	G.	Pressure Roller
B.	Spool Holder	H.	Liner
C.	Overload	I.	Wire Feed Roller
D.	Fuse Holder	J.	Pressure Adjust Knob
E.	Red Positive Terminal	K.	Inlet Guide
F.	Black Negative Terminal	L.	Tension Arm

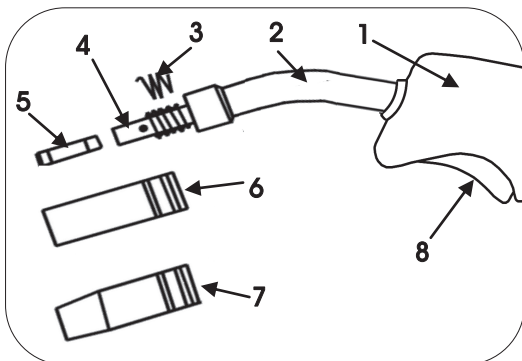

18

Ref. No.	Description
1.	Torch Handle
2.	Swan Neck
3.	Shroud Spring
4.	Gas Diffuser
5.	Mig Tip
6.	Conical Shroud
7.	Cylindrical Shroud
8.	Trigger Switch

## ASSEMBLY INSTRUCTIONS

### WELDING MASK ASSEMBLY

- The welding mask does not provide unlimited body protection.
- Use the welding mask only for eye and face protection from sparks, spatters and harmful rays from the mig welder.
- The filter lens is not suitable for any other application or process.
- To ensure your safety, we suggest using impact resistant flash goggles designed for eye protection when using this welding mask.
- Inspect the mask frequently, if damaged in any way **DO NOT** use it until the damaged parts have been replaced.

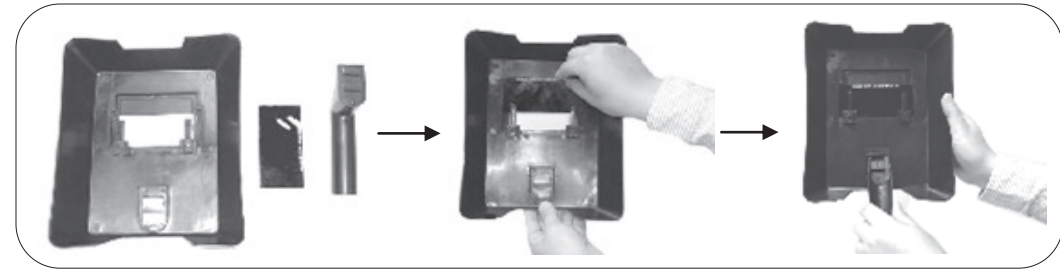

- Locate the welding mask, handle and filter lens (above, left).
- Slide the filter lens all the way down between the two lens holders (above, middle).
- Push the handle through the two slots on the bottom of the welding mask, once through push the handle up until the pin slots in to the hole on the mask.

### FITTING THE HANDLE

- Place the handle on top of the cover, check the small hole (see below pic) is at the front of the welder.
- Use both screws and washers supplied to secure it tightly to the cover.

Small hole  
(must be at the front of welder)



### MISCELLANEOUS

- **T136 and T166 only:** Connect the 6mm gas hose to the fitting on the rear of the machine use the hose clips to fix the hose, fit the bottle brackets into the slots on the rear panel of the welder.
- **T166 only:** Locate the mains lead and fit a suitably rated plug, consult the specification table and ratings label on the machine, in in doubt contact a local electrician.

19