



Please dispose of packaging for the product in a responsible manner. It is suitable for recycling. Help to protect the environment, take the packaging to the local amenity tip and place into the appropriate recycling bin.



Never dispose of electrical equipment or batteries in with your domestic waste. If your supplier offers a disposal facility please use it or alternatively use a recognised re-cycling agent. This will allow the recycling of raw materials and help protect the environment.

Sip
SIP INDUSTRIAL

machinery specialists since 1968

10" Compound Sliding Mitre Saw With Laser

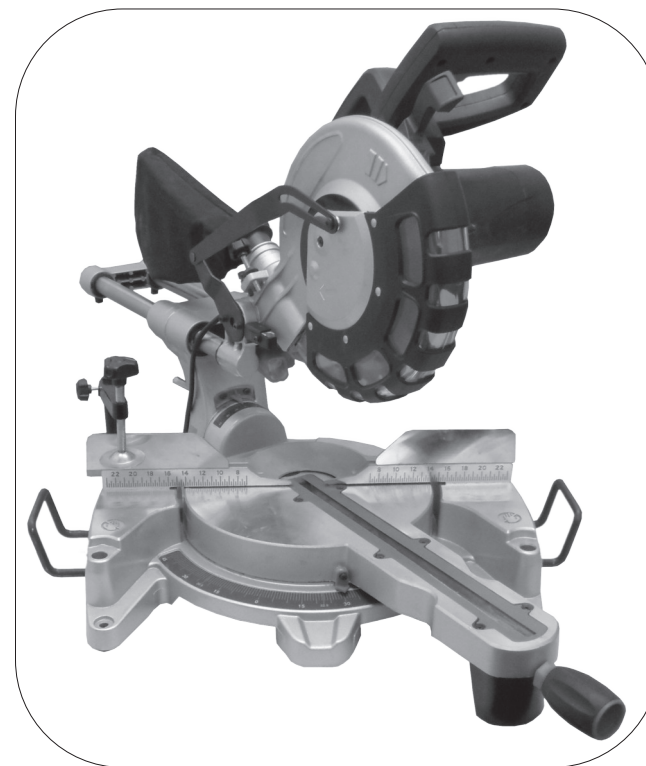

01511

**FOR HELP OR ADVICE ON THIS PRODUCT PLEASE CONTACT YOUR DISTRIBUTOR,
OR SIP DIRECTLY ON:
TEL: 01 509500400
EMAIL: sales@sip-group.com or technical@sip-group.com
www.sip-group.com**

Ref: 270214

Please read and fully understand the instructions in this manual before operation. Keep this manual safe for future reference.

DECLARATION OF CONFORMITY

Declaration of Conformity

We

SIP (Industrial Products) Ltd
Gelders Hall Road
Shepshed
Loughborough
Leicestershire
LE12 9NH
England

As the manufacturer's authorised representative within the EC
declare that the

10" Compound Sliding Mitre Saw - SIP Pt. No. 01511

Conforms to the requirements of the following directive(s), as indicated.

2006/95/EC	Low Voltage Directive
2006/42/EC	Machinery Directive
2004/108/EC	EMC Directive
2002/95/EC	ROHS Directive
As Amended By 2008/35/EC	

And the relevant harmonised standard(s), including,

EN 55014-1+A1:2009
EN 55014-2+A2:2008
EN 61000-3-2+A2:2009
EN 61000-3-11:2000

Signed:



Mr P. Ippaso - Managing Director - SIP (Industrial Products) Ltd
Date: 31/05/2013.



Page No.	Description
4.	Safety Symbols Used Throughout This Manual
4.	Safety Instructions
8.	Technical Specifications
9.	Electrical Connection
10.	Guarantee
10.	Contents and Accessories
11.	Getting To Know Your Saw
13.	Assembly Instructions
14.	Operating Instructions
19.	Maintenance
25.	Exploded Drawing
27.	Parts List
31.	Declaration of Conformity

SAFETY SYMBOLS USED THROUGHOUT THIS MANUAL



Danger / Caution: Indicates risk of personal injury and/or the possibility of damage.



Warning: Risk of electrical injury or damage!



Note: Supplementary information.

SAFETY INSTRUCTIONS



IMPORTANT: Please read the following instructions carefully, **failure to do so could lead to serious personal injury and / or damage to the mitre saw.**

When using electric tools, basic safety precautions should always be followed to reduce the risk of fire, electric shock and personal injury. Read all these instructions before operating the tool and save this user manual for future reference.

SIP recommends that this tool should **not** be modified or used for any application other than that for which it was designed. If you are unsure of its relative applications do not hesitate to contact us and we will be more than happy to advise you.

KNOW YOUR POWER TOOL: Read and understand the owner's manual and labels affixed to the tool. Learn its applications and limitations, as well as the potential hazards specific to this tool.

KEEP WORK AREA CLEAN AND WELL LIT: Cluttered work benches and dark areas invite accidents. Floors must not be slippery due to oil, water or sawdust etc.

DO NOT USE THE TOOL IN DANGEROUS ENVIRONMENTS: Do not use power tools in damp or wet locations, or expose them to rain. Provide adequate space surrounding the work area. Do not use in environments with a potentially explosive atmosphere.

KEEP CHILDREN AND UNTRAINED PERSONNEL AWAY FROM THE WORK AREA: All visitors should be kept at a safe distance from the work area.

STORE TOOLS SAFELY WHEN THEY ARE NOT IN USE: All tools should be stored in a dry, locked cupboard wherever possible and out of the reach of children.

WEAR THE CORRECT CLOTHING: Do not wear loose clothing, neckties, rings, bracelets, or other jewellery, which may get caught in moving parts. Non-slip footwear is recommended. Wear protective hair covering to contain long hair. Roll long sleeves up

PARTS LIST....cont

Ref. No.	Description	SIP Part No.	Ref. No.	Description	SIP Part No.
133.	Nylon hex. nut	WD01-00619	159.	Steel ball	WD01-00644
134.	Washer	WD01-00620	160.	Spring	WD01-00645
135.	Cap head bolt	WD01-00621	161.	Screw	WD01-00646
136.	Screw	WD01-00622	162.	Table bolt	WD01-00647
137.	Angle guide plate	WD01-00623	163.	Screw	WD01-00648
138.	Screw	WD01-00624	164.	Support wing	WD01-00649
139.	Table insert	WD01-00625	165.	Fence	WD01-00650
140.	Screw	WD01-00626	166.	Screw	WD01-00651
141.	Table	WD01-00627	167.	Fence extension	WD01-00652
142.	Mitre indicator	WD01-00628	168.	Screw	WD01-00653
143.	Screw	WD01-00629	169.	Clamp disc	WD01-00654
144.	Bushing	WD01-00630	170.	Clamp arm	WD01-00655
145.	Bushing cover	WD01-00631	170-1.	Complete clamp assembly	WD01-00656
146.	Screw	WD01-00632	171.	Clamp knob	WD01-00657
147.	Knob for extension arm	WD01-00633	172.	Clamp knob	WD01-00658
148.	Table front support	WD01-00634	173.	Clamp shaft	WD01-00659
149.	Locking shoe	WD01-00635	174.	Cap head bolt	WD01-00660
150.	Spring pin	WD01-00636	175.	Knob	WD01-00661
151.	Table locking bolt	WD01-00637	176.	Knob	WD01-00662
152.	Extension arm	WD01-00638	177.	Fence extension right	WD01-00663
153.	Lock handle	WD01-00639	178.	Cap head bolt	WD01-00664
154.	Screw	WD01-00640	179.	Washer	WD01-00665
155.	Lock handle cap	WD01-00641	181.	Washer	WD01-00666
156.	Base	WD01-00642	182.	Washer	WD01-00667
157.	Rubber foot	WD01-00643	183.	Dust bag	WD01-00668

PARTS LIST...cont

Ref. No.	Description	SIP Part No.	Ref. No.	Description	SIP Part No.
61.	Screw	WD01-00560	96.	Spring pin	WD01-00589
62.	Inner blade flange	WD01-00561	97.	Locking pin spring	WD01-00590
63.	Blade	Various	98.	Locking pin knob	WD01-00591
64.	Outer blade flange	WD01-00562	99.	Screw	WD01-00592
65.	Blade bolt	WD01-00563	100.	Spring washer	WD01-00593
67.	Special screw	WD01-00564	101.	Countersunk screw	WD01-00594
69.	Guard spring	WD01-00565	102.	Bearing cover	WD01-00595
70.	Screw	WD01-00566	103.	Screw	WD01-00596
72.	Guard plate	WD01-00567	104.	Guide bar end cap	WD01-00597
73.	Small retaining plate	WD01-00568	105.	Spring washer	WD01-00598
74.	Large retaining plate	WD01-00569	106.	Screw	WD01-00599
75.	Nut	WD01-00570	107.	Guide bar	WD01-00600
76.	Screw	WD01-00571	108.	Rubber ring	WD01-00601
77.	Lower blade guard	WD01-00572	109.	Linear bearing	WD01-00602
77-1.	Blade guard assembly	WD01-00573	110.	Bushing	WD01-00603
79.	Screw	WD01-00574	111.	Nylon hex. nut	WD01-00604
80.	Linkage assembly	WD01-00575	112.	Washer	WD01-00605
83.	Cap head bolt	WD01-00576	113.	Cap head bolt	WD01-00606
84.	Torsion spring	WD01-00577	114.	Knob	WD01-00607
85.	Spring bushing	WD01-00578	115.	Bevel lock handle	WD01-00608
86.	Depth stop plate	WD01-00579	116.	Washer	WD01-00609
87.	Spring piece	WD01-00580	117.	Nut	WD01-00610
88.	Wave washer	WD01-00581	118.	Cap head bolt	WD01-00611
89.	Screw	WD01-00582	119.	Saw arm	WD01-00612
90.	Retaining ring wire	WD01-00583	121.	Short stud	WD01-00613
91.	Pivot shaft	WD01-00584	122.	Long stud	WD01-00614
92.	Pivot bracket	WD01-00585	123.	Bevel pointer	WD01-00615
93.	Screw	WD01-00586	124.	Screw	WD01-00616
94.	Bearing cover	WD01-00587	126.	Screw	WD01-00617
95.	Locking pin	WD01-00588	129-1.	Laser assembly	WD01-00618

SAFETY INSTRUCTIONS...cont

above the elbow.

USE SAFETY GOGGLES AND EAR PROTECTION: Wear CE approved safety goggles at all times, Normal spectacles only have impact resistant lenses, they are **NOT** safety glasses. A face or dust mask should be worn if the operation is dusty and ear protectors (plugs or muffs) should be worn, particularly during extended periods of operation.

PROTECT YOURSELF FROM ELECTRIC SHOCK: When working with power tools, avoid contact with any earthed items (e.g. pipes, radiators, hobs and refrigerators, etc.). It is advisable wherever possible to use an RCD (residual current device) at the mains socket.

STAY ALERT: Always watch what you are doing and use common sense. Do not operate a power tool when you are tired or under the influence of alcohol or drugs.

DISCONNECT THE TOOL FROM THE MAINS SUPPLY: When not in use, before servicing and when changing accessories such as blades etc.

AVOID UNINTENTIONAL STARTING: Make sure the switch is in the **OFF** position before connecting the tool to the mains supply.

NEVER LEAVE THE TOOL RUNNING / CONNECTED WHILST UNATTENDED: Turn off the tool and disconnect it from the mains supply between jobs. Do not leave machine until it comes to a complete stop.

DO NOT ABUSE THE MAINS LEAD: Never carry the tool by the mains lead or pull it to remove the plug from the mains socket. Keep the mains lead away from heat, oil and sharp edges. If the mains lead is damaged, it must be replaced by the manufacturer or its service agent or a similarly qualified person in order to avoid unwanted hazards.

CHECK FOR DAMAGED PARTS: Before every use of the tool, a guard or other part that is damaged should be carefully checked to determine that it will operate correctly and perform its intended function. Check for alignment of moving parts, free running of moving parts, breakage of parts, and any other conditions that may affect its operation. A guard or other part that is damaged should be correctly repaired or replaced by an authorised service centre unless otherwise indicated in this instruction manual. Have defective switches replaced by an authorised service agent. Do not use the tool if the switch does not turn it on and off.

KEEP ALL GUARDS IN PLACE: And in full working order.

MAINTAIN TOOLS WITH CARE: Keep tools sharp and clean for the best and safest performance. Follow instructions for lubricating and changing accessories. All extension cables must be checked at regular intervals and replaced if damaged. Always keep the hand grip on the tool clean, dry and free of oil and grease.

USE ONLY RECOMMENDED ACCESSORIES: Consult this user manual for recommended accessories. Follow the instructions that accompany the accessories. The use of improper accessories may cause hazards and will invalidate any warranty you may have.

REMOVE ADJUSTING KEYS AND WRENCHES: Form a habit of checking to see that keys and adjusting wrenches are removed from the tool before every use.

SECURE THE WORK-PIECE: Use clamps or a vice to hold the work-piece. This frees up

SAFETY INSTRUCTIONS...cont

both hands to operate the tool.

DO NOT OVERREACH: Keep proper footing and balance at all times.

USE THE RIGHT TOOL: Do not use the tool or attachment to do a job for which it was not designed.

DO NOT FORCE THE TOOL: It will do the job better and more safely at the rate which it was designed.

DO NOT OPERATE POWER TOOLS IN EXPLOSIVE ATMOSPHERES: Do not use the tool in the presence of flammable liquids, gases, dust or other combustible sources. Power tools may create sparks which can ignite the dust or fumes.

DO NOT EXPOSE THE TOOL TO RAIN OR USE IT IN WET CONDITIONS: Water entering a power tool will greatly increase the risk of electric shock.

- Use only the blade flange specified for this tool.
- Before each use; Ensure that the blade retaining bolt is fully secure.
- Make sure that the table base is properly secured so it will not move during operation.
- For your safety; remove the chippings and work debris etc. from the table top and from inside the extraction port before each operation.
- Avoid cutting nails / screws etc.; Remove all obstructions from the work-piece before cutting.
- Make sure that all keys and wrenches are removed before switching on the saw.
- Keep hands out of path of the saw blade, never reach around saw blade.
- Make sure the blade is clear of the work-piece before the switch is turned on.
- Before making the first cut using the saw, turn the blade by hand to ensure nothing is catching, then turn the saw on and let it run for a while; Watch for vibration or wobbling that could indicate poor installation or a poorly balanced blade. Adjust or replace as necessary.
- Allow the blade to run up to full speed before cutting.
- Stop operation immediately if you notice anything abnormal.
- Wait for the saw blade to stop completely and remove from mains supply before servicing or adjusting the saw.
- Be alert at all times, especially during repetitive, monotonous operations. Don't be lulled into a false sense of security. Blades are extremely unforgiving.
- Use of improper accessories such as abrasive wheels may cause damage to the saw and surrounding area as well as increasing the risk of injury.
- Turn off the saw and wait for it to complete stop before moving work-piece or changing settings.
- Do not modify the saw to do tasks other than those intended.
- Do not perform any operation freehand. The work-piece must be secured firmly against the base and guide fence with the clamp during all operations; Using your hand may cause severe injury.

PARTS LIST

Ref. No.	Description	SIP Part No.	Ref. No.	Description	SIP Part No.
1.	Cap	WD01-00500	31.	Mains leads holder	WD01-00530
2.	Self tapping screw	WD01-00501	32.	Self tapping screw	WD01-00531
3.	Motor cover	WD01-00502	33.	Transformer	WD01-00532
4.	Self tapping screw	WD01-00503	34.	Screw	WD01-00533
5.	Carbon brush (set of 2)	WD01-00504	35.	Trigger	WD01-00534
6.	Carbon brush spring	WD01-00505	36.	Mains lead	WD01-00535
7.	Brush holder	WD01-00506	37.	Mains lead protector	WD01-00536
8.	Screw	WD01-00507	38.	Screw	WD01-00537
9.	Spring washer	WD01-00508	39.	Carrying handle	WD01-00538
10.	Washer	WD01-00509	40.	Carrying handle cover	WD01-00539
11.	Motor housing	WD01-00510	41.	Self tapping screw	WD01-00540
12.	Bearing cover	WD01-00511	42.	Self tapping screw	WD01-00541
13.	Wave washer	WD01-00512	43.	Upper handle	WD01-00542
14.	Bearing	WD01-00513	44.	Terminal block	WD01-00543
15.	Armature	WD01-00514	45.	Trigger switch	WD01-00544
16.	Field coil	WD01-00515	46.	Lower handle	WD01-00545
17.	Self tapping screw	WD01-00516	47.	Screw	WD01-00546
18.	Wind guard	WD01-00517	48.	Nut	WD01-00547
19.	Bearing	WD01-00518	49.	Depth adjust knob	WD01-00548
20.	Gear casing	WD01-00519	50.	Special nut	WD01-00549
21.	Screw	WD01-00520	51.	Upper blade guard	WD01-00550
22.	Spring washer	WD01-00521	52.	Needle bearing	WD01-00551
23.	Washer	WD01-00522	53.	Retaining ring shaft	WD01-00552
24.	Anti finger plate	WD01-00523	54.	Gear	WD01-00553
25.	Gear lock pin spring	WD01-00524	55.	Gear bushing	WD01-00554
26.	Gear lock pin	WD01-00525	56.	Key	WD01-00555
27.	Gear lock button	WD01-00526	57.	Arbor shaft	WD01-00556
28.	Self tapping screw	WD01-00527	58.	Bearing	WD01-00557
29.	Laser switch	WD01-00528	59.	Screw	WD01-00558
30.	Laser switch button	WD01-00529	60.	Gear case cover	WD01-00559

EXPLODED DRAWING B

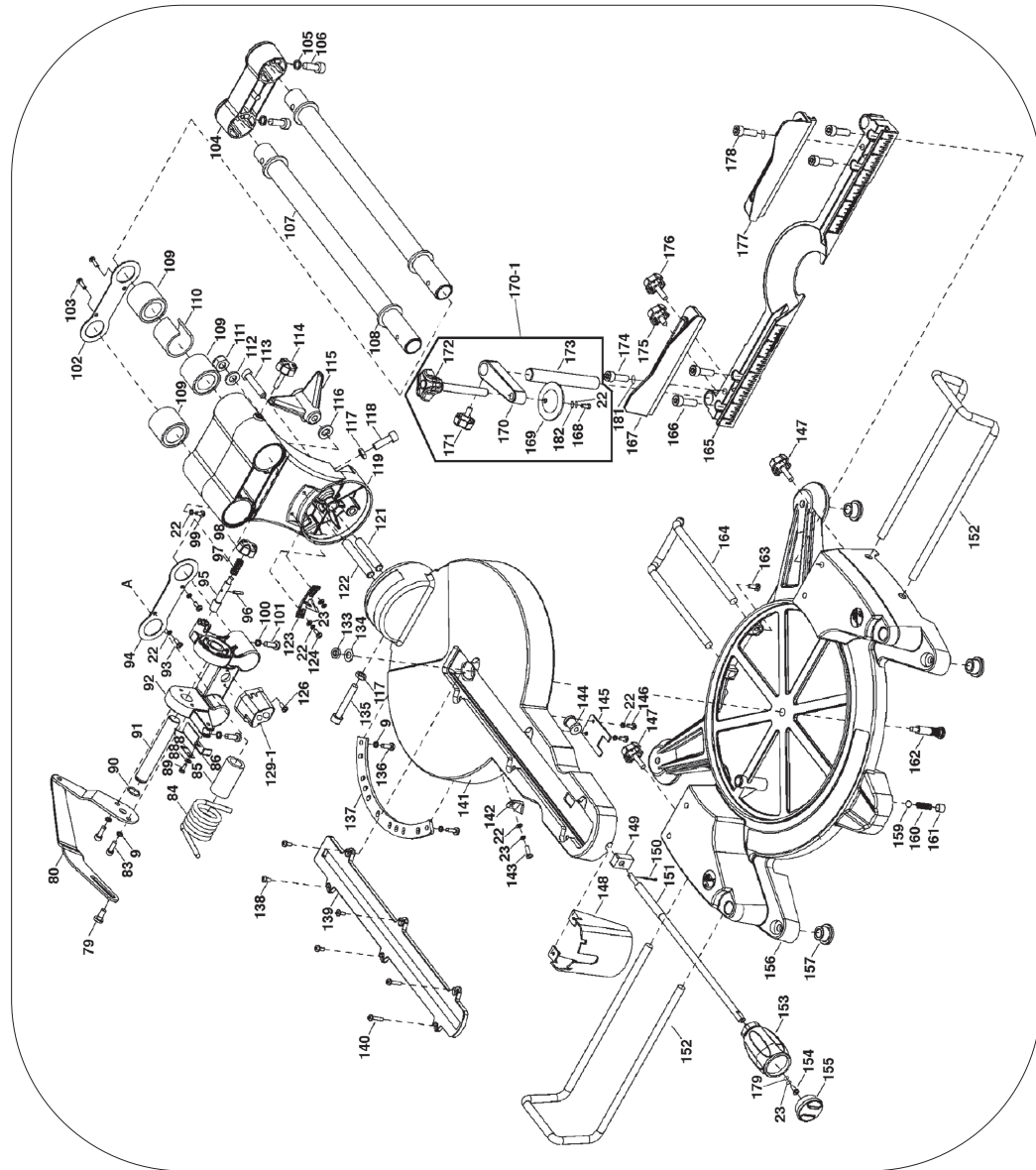

SAFETY INSTRUCTIONS...cont



Warning: The laser beam can potentially cause severe eye damage. Never look or stare directly into the laser beam.

Warning: During use, do not point the laser beam at people, directly or indirectly through reflecting surfaces.

- This laser complies with class 2 according to EN 60825-1:2007.
- The unit includes no servicing components. Do not open the housing for any reason. If the unit is faulty/damaged, have it repaired/replaced by an authorised repair agent.
- Do not stare directly at the laser beam, never aim the beam at any person or an object other than the work-piece.
- Do not deliberately aim the beam at personnel and ensure that it is not directed towards the eye of a person.
- Always ensure the laser beam is aimed at a sturdy work-piece without reflective surfaces. wood or rough coated surfaces are acceptable. Bright shiny reflective surfaces are not suitable for laser use as the reflective surface could direct the beam back at the operator.
- Always remember to switch off the laser on/off switch (25) after finishing a job, only turn the laser beam on when the work-piece is on the mitre saw table.



When using the saw always ensure the operator as well as those in the area wear ear protection.



When using the saw always ensure the operator as well as those in the area wear eye protection.



Some wood and wood composites have the potential to be highly toxic; always wear a face mask when operating saw.

SAFETY INSTRUCTIONS...cont

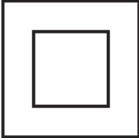

This mitre saw is double insulated; This means the operator is separated from the tool's electrical system by two complete sets of electrical insulation. This extra layer of insulation is intended to protect the user from electrical shock due to a break in the wiring insulation. All exposed metal parts are isolated from the internal metal motor components with protecting insulation. Double insulated tools do not need to be grounded (earthed). Servicing of a tool with double insulation requires extreme care and knowledge of the system and should be performed only by a suitably qualified person.



Caution: The warnings and cautions mentioned in this user manual can not cover all possible conditions and situations that may occur. It must be understood by the operator that common sense and caution are factors which cannot be built into this product, but must be applied.

TECHNICAL SPECIFICATIONS

Part number	01511
Input voltage	230v ~ 50hz
Power	2000 w
No load speed	5500 rpm
Blade Ø	254 mm
Blade bore	30 mm
Mitre table angles	-45° - +45°
Straight cut at 0° x 0°	340mm x 80mm
Mitre cut at 45° x 0°	240mm x 80mm
Bevel cut at 0° x 45°	340mm x 50mm
Compound mitre cut at 45° x 45°	240mm x 50mm
Weight	18kg

EXPLODED DRAWING A

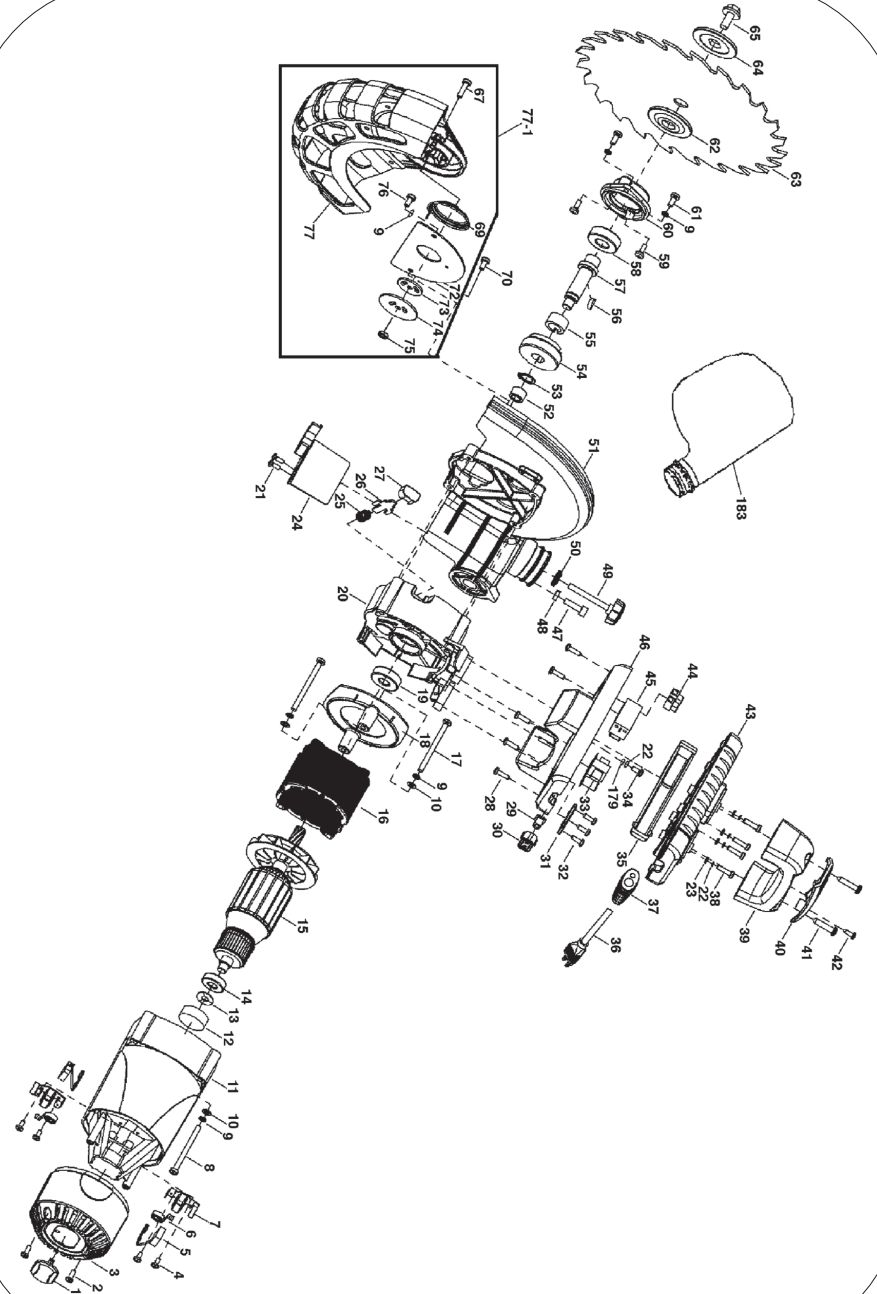

MAINTENANCE...cont

- The motor of the saw should be cleared of any wood chippings as there would be a risk of fire if they are allowed to build up over time (a soft brush or dry air could be used to clear the motor).
- Empty the bag at least after each use; the bag should be emptied before it gets half full to ensure its efficiency. There is a zip on the bag to allow for easy disposal of wood chippings.
- Ensure the blade guard is kept clean with a damp cloth (do not clean the guard or any part of the saw with a corrosive solvent) to reduce the risk of injury. Periodically oil all the moving parts on the saw to extend the life of the saw.



Caution! Water must never come into contact with the tool.

ELECTRICAL CONNECTION



This mitre saw is double insulated. This means the operator is separated from the tool's electrical system by two complete sets of electrical insulation.

This saw is fitted with a standard UK type 230v ~ plug. Before using the tool inspect the cable and plug to ensure that neither are damaged. If any damage is visible have the tool inspected / repaired by a suitably qualified person. If it is necessary to replace the plug a heavy duty impact resistant plug would be preferable.

The wires for the plug are coloured in the following way:

Blue	Neutral
Brown	Live

As the colours of the wires may not correspond with the markings in your plug, proceed as follows:

- The wire which is coloured blue, must be connected to the terminal marked with N or coloured black.
- The wire which is coloured brown, must be connected to the terminal, which is marked L or coloured red.
- Always secure the wires in the plug terminal carefully and tightly. Secure the cable in the cord grip carefully.



Warning: Never connect live or neutral wires to the earth terminal of the plug. Only fit an approved plug with the correct rated fuse. If in doubt consult a qualified electrician.



Note: Always make sure the mains supply is of the correct voltage and the correct fuse protection is used. In the event of replacing the fuse always replace the fuse with the same value as the original.



Note: If an extension lead is required in order to reach the mains supply; ensure that this too is rated for the correct voltage and fuse rating.



Note: The cross section of the extension lead should be checked so that it is of sufficient size so as to reduce the chances of voltage drops.

GUARANTEE

This SIP 10" compound sliding mitre saw is covered by a 12 month parts and labour warranty covering failure due to manufacturers defects. This does not cover failure due to misuse or operating the saw outside the scope of this manual - any claims deemed to be outside the scope of the warranty may be subject to charges including, but not limited to parts, labour and carriage costs. Consumable items such as fuses, blades and motor brushes are not covered by the warranty.

This saw is designed to **ONLY** cut wood or wood derived products.

In the unlikely event of warranty claims, contact your distributor as soon as possible. Proof of purchase will be required before any warranty can be honoured.



Note: Proof of purchase will be required before any warranty can be honoured.

CONTENTS AND ACCESSORIES

- Dust Bag
- Work-piece Clamp
- Blade Wrench
- Instruction Manual



Note: If any parts are missing, contact your distributor for the missing parts to be replaced.

MAINTENANCE...cont

down to the limit mark, see Fig.6. Keep the carbon brushes clean and free to slip in the holders.

If they have worn down to the limit mark, purchase a set of identical replacement carbon brushes (both carbon brushes should be replaced at the same time). Insert new carbon brushes into the holders, connect them to the terminals, reposition the retaining spring and reinstall the motor housing cap using the 2 pan head screws.

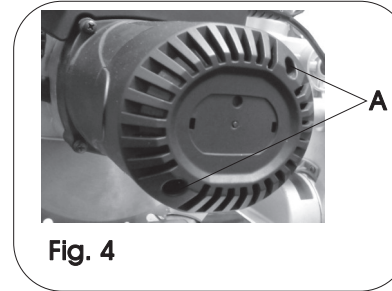

Fig. 4

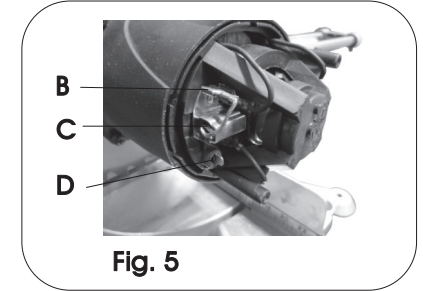

Fig. 5

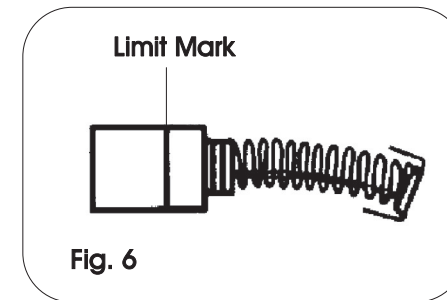

Fig. 6

GENERAL CLEANING

Cleaning and maintenance of this saw is mainly common sense some points for guidance are as follows:

- Regularly check that all the fixing screws are tight, particularly the outer flange. They may vibrate loose over time.
- The mains lead of the saw and any extension cord used should be checked frequently for damage. If damaged, have the mains lead replaced by an authorised service facility. Replace the extension cord if necessary.
- Keep the air vents of the saw clear at all times.
- After each use brush off any wood chippings with a soft brush. Pay special attention to the inside of the dust extraction port (where the dust bag fits to the saw) as this is where there will be a large build up if left for extended periods.

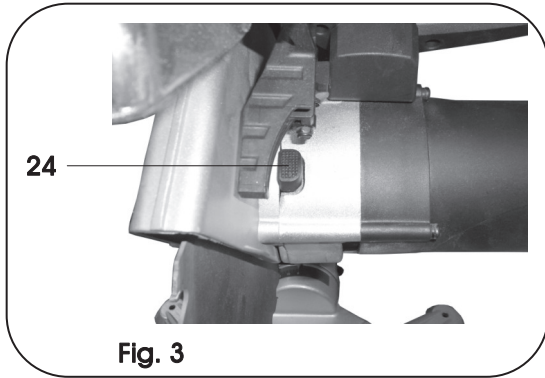

Fig. 3

- Remove the outer blade flange and the blade.
- Wipe a drop of oil onto the inner and outer blade flanges.
- Fit the new blade onto the spindle, make sure that the blade has the appropriate dimensions and that the inner blade flange sits properly behind the blade.



Caution: Always install the blade with the blade teeth pointing downwards. The direction of the blade rotation is also stamped with an arrow on the blade guard.

- Reposition the outer blade flange.
- Depress the spindle lock, reposition and secure the blade bolt using the blade wrench; Tighten the blade bolt in a counter-clockwise direction as the blade bolt has a left hand thread.
- Follow the previous instructions in reverse to refit the blade guard etc.



Caution: Ensure all screws / bolts are completely tight and that the blade guard works correctly before re-using the saw.

REPLACING THE CARBON BRUSHES

Remove and check the carbon brushes regularly (normally after 50 hours of use). The carbon brushes are installed inside the motor housing. Using a screwdriver, remove the 2 pan head screws (A) Fig.4 that hold the motor housing cap in place. Once the motor housing cap is removed, release the carbon brush (C) Fig. 5 from the holder, lower the retaining spring (D). Disconnect the carbon brush wire from the terminal (B), remove the carbon brush from the motor housing and inspect it. Repeat this step for the second carbon brush. Carbon brushes need to be replaced once they wear

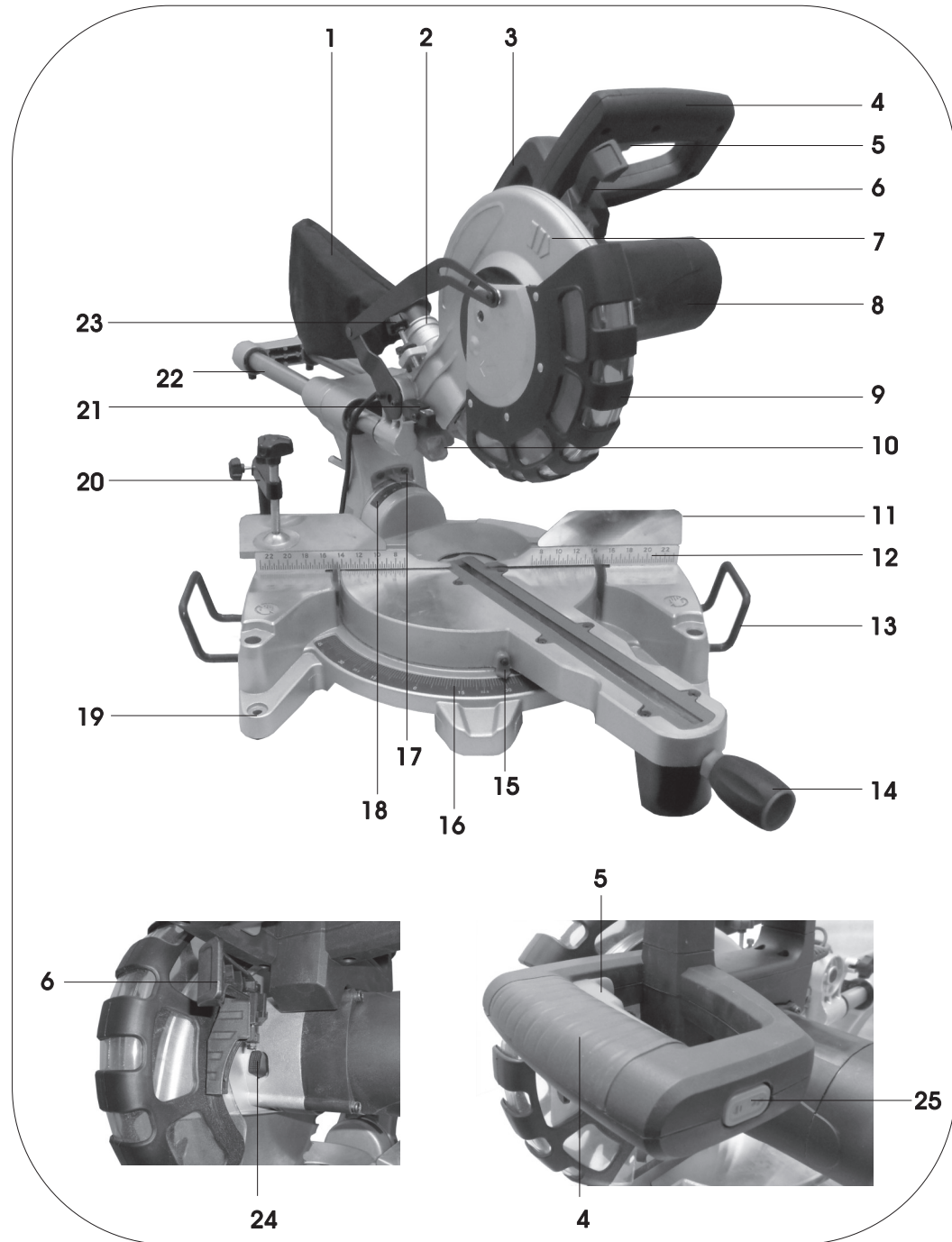

GETTING TO KNOW YOUR SAW....cont

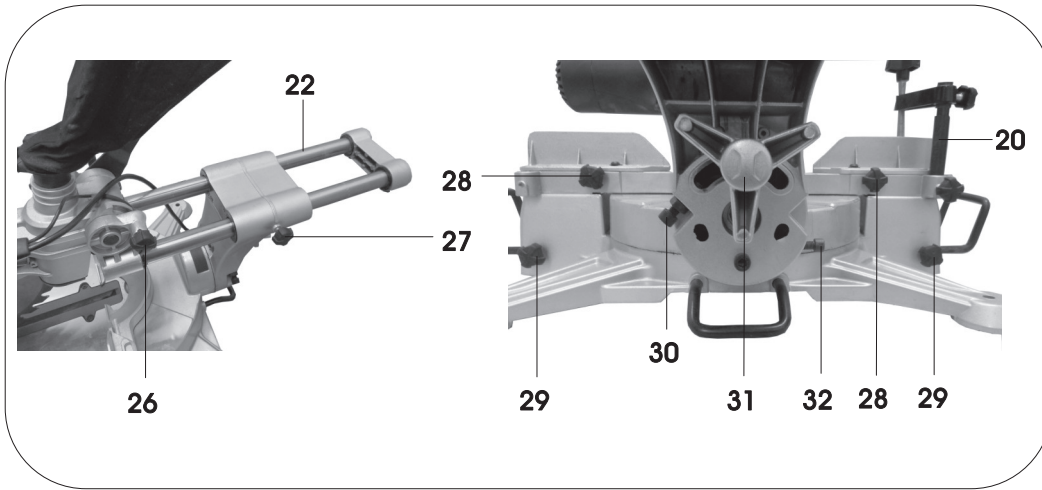

Ref. No.	Description	Ref. No.	Description
1.	Dust Collection Bag	17.	Bevel Angle Pointer
2.	Dust Collection Port	18.	Bevel Angle Scale
3.	Carrying Handle	19.	Workbench Mounting Hole
4.	Operating Handle	20.	Work-piece Clamp
5.	On/Off Trigger Switch	21.	Depth Stop
6.	Blade Guard Release Lever	22.	Sliding Rail
7.	Upper Blade Guard	23.	Depth Stop Adjuster
8.	Motor	24.	Spindle Lock
9.	Lower Blade Guard	25.	Laser On/Off Switch
10.	Laser	26.	Saw Head Release
11.	Rear Fence Extension	27.	Sliding Rail Lock
12.	Rear Fence	28.	Fence Extension Lock
13.	Adjustable Side Rail Support	29.	Side Rail Lock
14.	Mitre Angle Lock	30.	Bevel Angle Adjust (90°)
15.	Mitre Angle Pointer	31.	Bevel Angle Lock
16.	Mitre Angle Scale	32.	Bevel Angle Adjust (45°)

MAINTENANCE....cont

- Loosen the locking nut on the bevel angle adjust bolt (45°) (32).
- Turn the angle adjust bolt (32) until an angle of 45° is achieved.
- Lock off the locking nut whilst ensuring that the angle kept.
- Check if the bevel angle pointer is pointing to 45° and adjust as necessary.

CHANGING / INSTALLING THE BLADE



Caution: Always ensure that the replacement blade matches the specifications, as shown on page 8. **Never** fit a blade which is smaller or bigger than that stated.

- Pull on the saw head release knob (26) and turn it through 90° to lock it "open"
- lift the operating handle (4) to its full height.
- Unscrew and remove large screw (A) Fig.1, and move the blade guard pivot link arm (B) out of the way.
- Unscrew and remove pan head screw (C) which fixes the guard plate and lower blade guard to the upper blade guard.

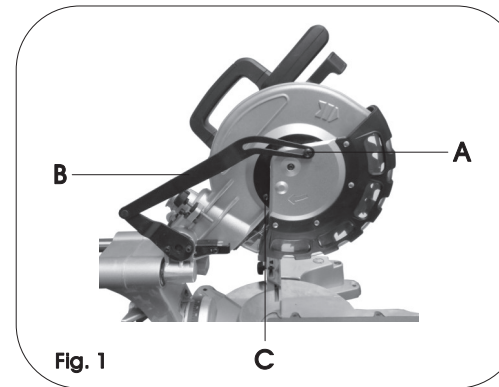

Fig. 1

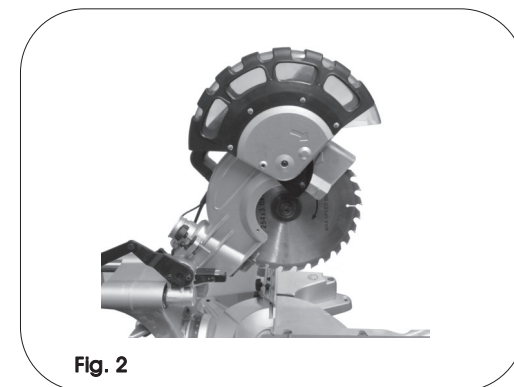

Fig. 2

- Once the pan head screw (C) is removed, swing the guard plate and lower blade guard upwards to allow access to the blade bolt as shown in Fig.2.
- Completely depress the spindle lock button (24) Fig. 3, page 22 using one hand.
- Whilst keeping the spindle locked; Rotate the blade by hand until the spindle locks.
- Use the supplied blade wrench to remove the blade retaining bolt.



Note: loosen in a clockwise direction as the blade bolt has a left hand thread.

MAINTENANCE...cont

CHECKING AND SETTING THE BEVEL ANGLE @ 90°

- Loosen the sliding rail lock (27); push the saw head back as far as it will go and re-tighten the sliding rail lock (27).
- Loosen the mitre lock (14); turn the main table until the positive stop for 0° engages and the angle guide pointer shows 0°.
- Re-tighten the mitre lock.
- Place a 90° square against the blade and the table; If the angle is not exactly 90°.

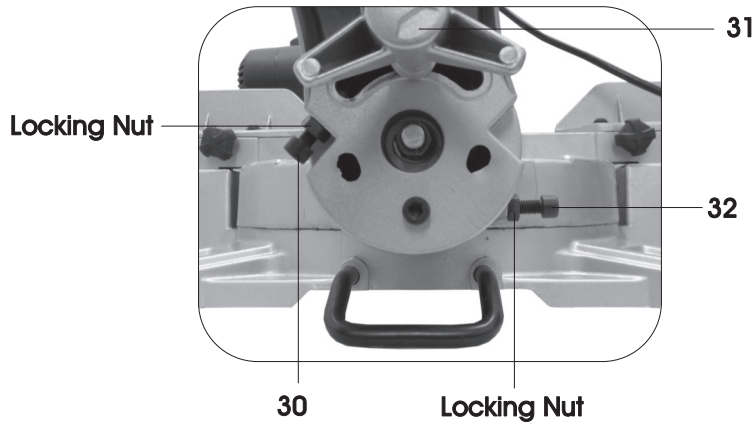

- Loosen the locking nut on the bevel angle adjust bolt (90°) (30).
- Loosen the bevel angle lock (31).
- Turn the angle adjust bolt (30) until an angle of 90° is achieved.
- Lock off the locking nut whilst ensuring that the angle kept.
- Check if the bevel angle pointer is pointing to 0° and adjust as necessary.

CHECKING AND SETTING THE BEVEL ANGLE @ 45°

- Loosen the sliding rail lock (27); push the saw head back as far as it will go and re-tighten the sliding rail lock (27).
- Loosen the mitre lock (14); turn the main table until the positive stop for 0° engages and the angle guide pointer shows 0°.
- Re-tighten the mitre lock.
- Loosen the bevel angle lock (31).
- Push the saw head as far to the left (to 45°) as it will go.
- Place a set square with an accurate 45° angle against the main table of the saw and the blade; If the angle is not exactly 45°.

ASSEMBLY INSTRUCTIONS

FITTING THE DUST COLLECTION BAG

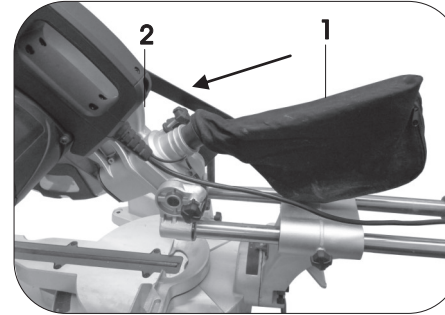

Fit the dust collection bag (1) into the dust collection port (2).



Note: For efficient operation, empty the dust bag when it is no more than half full, this allows better air flow through the bag.



Note: For more efficient dust removal; The dust bag should be removed and a separate dust extractor could be used.

FITTING THE WORK-PIECE CLAMP:



The work-piece clamp (20) can be fitted to either side of the saw blade depending on the work-piece size and the type of cut being performed.

Slide the column of the clamp into the clamp retainer and secure by tightening the thumbscrew.



Note: The height and depth etc. of the clamp should be set according to the work-piece / type of cut being performed.

OPERATING INSTRUCTIONS



Warning: Do not stare into the laser beam as this is dangerous and will damage your eyes.

- Do not stare directly at the laser beam, never aim the beam at any person or an object other than the work-piece.
- Do not deliberately aim the beam at people or animals, particularly towards the eyes.
- Do not use the laser if the work-piece has reflective surfaces. Wood or rough coated surfaces are acceptable, bright shiny reflective surfaces are not suitable for laser use as the reflective surface could direct the beam back at the operator.
- Always remember to switch off the laser on/off switch (25) after finishing the job; only turn the laser beam on when the work-piece is on the mitre saw table.



Note: When cutting long pieces of timber use the side rail supports, if cutting extra long timber, a roller stand or a work surface that is level with the saw table should be utilised.

CROSS-CUTTING (WITHOUT SLIDE ACTION)



Note: When cutting a narrow piece of wood it is not necessary to use the slide mechanism; In these cases ensure that the saw head is pushed back and the slide lock (27) is tight to prevent the saw arm from sliding.

A crosscut is made by cutting across the work-piece; a 90° crosscut is made with the mitre table set at 0°. Mitred crosscuts are made with the table set at any other angle.

- Pull on the saw head release knob (26) and turn it through 90° to lock it "open".
- lift the operating handle (4) to its full height.
- Loosen the mitre angle lock (where applicable) (14).
- Rotate the mitre table until the pointer (15) aligns with the desired angle on the scale (16).
- Retighten the mitre angle lock (14).



Warning! Ensure the mitre lock is fully tightened before making a cut; Failure to do so could result in the table moving during the cut and cause serious personal injury, and damage the work-piece / saw.

MAINTENANCE



Warning! Always ensure that the saw is turned off and that the plug is disconnected from the mains supply before carrying out any adjustments, repairs or maintenance.

This saw is set up at the factory and should need no adjustment; however time and careless use can affect the angles and some adjustment may be required.

CHECKING AND SETTING THE MITRE ANGLE

- Loosen the sliding rail lock (27); push the saw head back as far as it will go and re-tighten the sliding rail lock (27).
- Loosen the mitre angle lock (14); turn the main table until the positive stop for 0° engages and the mitre angle pointer (15) is close to 0°.
- Re-tighten the mitre angle lock (14).
- If the mitre angle pointer (15) is not exactly set to 0° loosen the screw and turn the pointer until it is.
- Loosen the 4 (2 on each side of the saw) rear fence locking bolts and lower the blade to its lowest point; lock the saw head down with the saw head release (26).

Rear Fence Locking Bolts

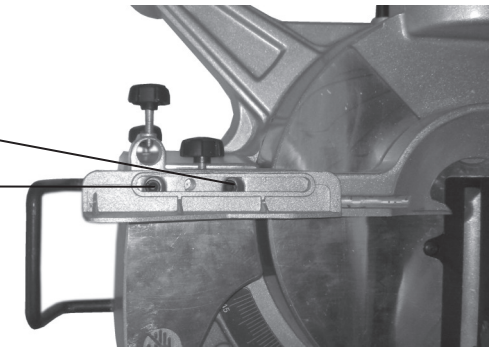

- Place a square against the blade and rear fence and adjust the fence until an angle of exactly 90° is achieved.
- Proceed to tighten the rear fence locking bolts whilst ensuring that an angle of 90° is maintained.

OPERATING INSTRUCTIONS...cont

Function:

Once the depth stop is set; the blade will not cut all the way through the work-piece (depending on the depth that it is set to). This will allow the operator to easily cut slots out of the work-piece if used in conjunction with the sliding function of the saw. It is advisable to check the cut depth on a scrap piece of wood.

Set the required angles etc. and proceed to cut as explained earlier in this manual.



Note: It may be necessary to clean the slot with a sharp chisel or by sanding.

OPERATING INSTRUCTIONS...cont

- Place the work-piece flat on the table with one edge securely against the fence (12).
- Use the clamp assembly (20) to secure the work-piece.



Note: The work-piece clamp (20) can be fitted to either side of the saw blade depending on the work-piece size and the type of cut being performed; Always ensure the clamp is secure before operation.

- Turn on the laser by pressing the laser On/Off switch (25).
- Hold the operating handle (4) firmly and squeeze the trigger switch (5); allow the blade to reach maximum speed.
- Press the blade guard release lever (6) and slowly lower the blade onto and through the work-piece.
- Release the trigger switch (5) and allow the saw blade to stop rotating before raising the blade away from the work-piece.
- Ensure that the blade has stopped and that the saw head is returned to a position so that the guard is covering the blade before removing the work-piece from the table.

CROSS-CUTTING (WITH SLIDE ACTION)

- Unscrew the sliding rail lock (27).
- Pull on the saw head release knob (26) and turn it through 90° to lock it "open"
- Lift the operating handle (4) to its full height and slide (pull) it towards you.
- Loosen the mitre angle lock (where applicable) (14).
- Rotate the mitre table until the pointer (15) aligns with the desired angle on the scale (16).
- Retighten the mitre angle lock (14).



Warning! Ensure the mitre lock is fully tightened before making a cut; Failure to do so could result in the table moving during the cut and cause serious personal injury, and damage the work-piece / saw.

- Place the work-piece flat on the table with one edge securely against the fence (12).
- Use the clamp assembly (20) to secure the work-piece.



Note: The work-piece clamp (20) can be fitted to either side of the saw blade depending on the work-piece size and the type of cut being performed; Always ensure the clamp is secure before operation.

OPERATING INSTRUCTIONS...cont

- Turn on the laser by pressing the laser On/Off switch (25).
- Hold the operating handle (4) firmly and squeeze the trigger switch (5); allow the blade to reach maximum speed.
- Press the blade guard release lever (6) and slowly lower the blade onto and through the work-piece whilst sliding (pushing) the handle away from you at the same time until the work-piece is cut.
- Release the trigger switch (5) and allow the saw blade to stop rotating before raising the blade out of the work-piece.
- Ensure that the blade has stopped and that the saw head is returned to a position so that the guard is covering the blade before removing the work-piece.

MAKING A BEVEL CUT

A bevel cut of up to 45° (to the left) can be achieved by using the following method:

- Loosen the bevel lock handle (31) which is situated at the rear of the saw.
- Use the bevel angle scale (18) and pointer (17) to set the head to the desired angle.
- Tighten the bevel lock handle (31) to secure the head at the desired angle.

Follow the previous instructions to perform the cut depending on the dimensions of the work-piece (see "cross cut with sliding action" or "cross cut without sliding action").

MAKING A MITRE CUT

A mitred angle of 45° left or right can be obtained using the following method.

- Loosen the mitre angle lock (14).
- Turn the table until the desired angle is indicated by the mitre angle pointer (15) on the mitre angle scale (16).



Note: The mitre angle guide has positive stops at popular angles 15°, 22.5°, 30° & 45° left and right, but any angle between 0° and 45° can be selected by tightening the mitre lock at the desired angle (14).

- Tighten the mitre lock (14) to hold the desired angle.

Follow the previous instructions to perform the cut depending on the dimensions of the work-piece (see "cross cut with sliding action" or "cross cut without sliding action").

OPERATING INSTRUCTIONS...cont

MAKING A COMPOUND MITRE CUT

A compound mitre cut involves using a mitre angle and a bevel angle at the same time. It is used in making picture frames, to cut mouldings, making boxes with sloping sides and for roof framing. Use the slide action when cutting wider work-pieces.

Follow the previous instructions to set both angles and to complete the cut.



Note: It is a good idea to make a test cut on a piece of scrap wood before cutting into the good material.

USING THE DEPTH STOP

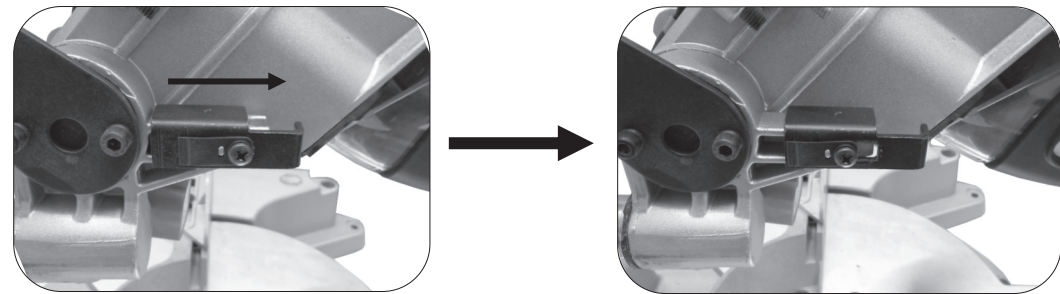

- Slide the depth stop bracket (21) to the right to engage the depth stop.

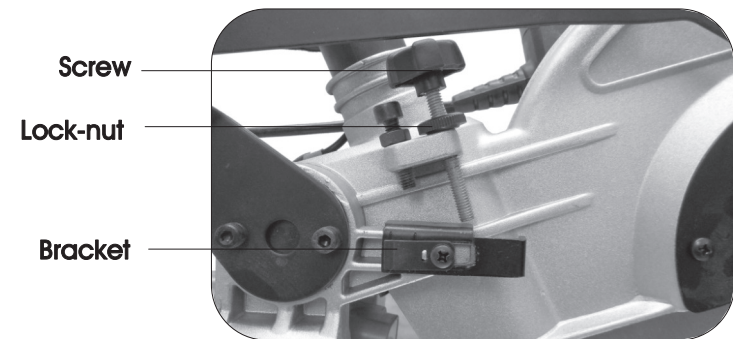

- Loosen the lock-nut.
- Adjust screw to the required depth.
- Once set to the desired depth; Tighten the lock-nut against the retaining bracket to lock the depth stop and ensure there is no movement due to vibration etc.